



[More Info](#) | [Instructions](#) | [Get Quote](#)

# Waterloo Multilevel Groundwater Monitoring System

## Assembly Manual

February 14, 2020

**Solinst**<sup>®</sup>

**Waterloo**  
Multilevel System



**Table of Contents**

<b>Waterloo Multilevel System Pre-installation Requirements</b>	<b>1</b>
<b>1.0 Introduction</b>	<b>2</b>
<b>2.0 Installation Components</b>	<b>3</b>
<b>3.0 Preparation</b>	<b>4</b>
<b>4.0 Assembling the System</b>	<b>5</b>
<b>5.0 Joint Connections</b>	<b>8</b>
<b>6.0 Port Connections</b>	<b>10</b>
6.1 Attaching Open Tubes	10
6.2 Attaching Vibrating Wire Transducers (VWT)	11
6.3 Attaching a Pump (Bladder or Double Valve)	14
<b>7.0 Testing Monitoring Equipment</b>	<b>16</b>
<b>8.0 Packer Activation</b>	<b>17</b>
<b>9.0 Wellhead Manifold Completion</b>	<b>18</b>
9.1 Standard Option	18
9.2 Multipurge Option	19
9.3 Wellhead Protection	20
<b>10.0 Monitoring Options</b>	<b>21</b>
<b>Appendix</b>	
- Waterloo System Installation Field Log	I
- Vibrating Wire Transducer Calibration Report	II
- Sample Vibrating Wire Calculation	III
- Training Terms and Conditions	IV



## Waterloo Multilevel System Pre-installation Requirements

Please complete this form to verify that proper consideration has been given to design and borehole specifications for each Waterloo Multilevel System to be installed.

### 1/ Minimum information required for effective design of the Waterloo Multilevel System:

Accurate borehole depth \_\_\_\_\_ Borehole angle \_\_\_\_\_  
Depth to which Waterloo System is to be installed \_\_\_\_\_  
Borehole geology \_\_\_\_\_ Drilling method \_\_\_\_\_  
Casing size (minimum ID) \_\_\_\_\_ Depth to base of well casing \_\_\_\_\_  
\*Borehole diameter (max and min) \_\_\_\_\_  
Approximate depth to static water level \_\_\_\_\_  
Expected pressure heads at each monitoring zone \_\_\_\_\_  
Number of monitoring zones \_\_\_\_\_  
Desired port and packer locations/depths \_\_\_\_\_  
Site conditions (e.g. dry field, bush, swamp, paved, etc.) \_\_\_\_\_  
Any special surface requirements for completion \_\_\_\_\_  
of installation (e.g. flush mounted, angled, etc)  
Monitoring equipment required \_\_\_\_\_  
(double valve pumps, bladder pumps, vibrating wire transducers, water level meters for open tubes, etc.)

**\*Note:** Boreholes must be stable, circular, smooth and straight for best packer seal.

***Using the layout of monitoring equipment at the proposed depth, Solinst can assist the client in determining the appropriate number of components to achieve your proposed monitoring scenario for the Waterloo Multilevel System. Final design and installation details remain the responsibility of the purchaser. Call for details about installation training.***

### 2/ Ensure that these additional items are available on site during installation:

- Suitable and safe working area
- Clean water (~20 US gal (75 L)/30 m (100 ft.) installation)
- Compressed air or nitrogen to test pumps if installed
- Proper regulator for compressed air or nitrogen cylinder
- Pump Controller for testing pumps
- Readout unit to read Vibrating Wire Transducers
- Water Level Meter to check levels during installation
- Device to check total depth of borehole
- At least two client representatives for the installation
- Support device to assist in lowering Systems where depth to water is deeper than 30 m (100 ft.)

## **1.0 Introduction**

The Waterloo Multilevel Monitoring System is comprised of modular units designed to allow discrete monitoring from several zones within a single borehole. A variety of portable and dedicated instrumentation allows users to retrieve samples, determine piezometric head, temperatures, and conduct basic hydraulic conductivity tests at each zone.

The System uses modular components of various casing lengths, which form a sealed casing string. Sampling Ports are usually isolated using Packers, or alternating layers of sand and seal for direct burial option. All instrument tubing and cabling is contained within these modules and collected at the top of the system into an efficient and simple Wellhead Manifold.

This manual describes the above-ground assembly of the Waterloo System, including: preparation, joint connections, port connections, testing monitoring equipment, packer activation, and manifold completion.

For best results, please review this entire manual before proceeding with your installations.

## 2.0 Installation Components

Individual components of the Waterloo Multilevel System include: PVC Casing, stainless steel Base Plug or PVC Base Plug, stainless steel Ports (single and dual stem), Permanent Packers, and Wellhead Manifolds. Components are shown in Figure 2-1.



Figure 2-1 Installation Components

**! NOTE**

In designing the layout, it is preferable to allow one to two feet of clearance above the bottom of the borehole. Problems of measurement inaccuracy, sloughing during installation, and other unforeseen events which may prevent well completion are thus minimized.

**! NOTE**

If the depth to water is greater than 30 m (100 ft.) below ground surface, lower the system with the support cable and drilling rig.

**! NOTE**

Be sure to document the position and placement of each downhole component, during the installation. An 'as built' installation log is a crucial part of knowing where each monitoring zone is placed.

### **3.0 Preparation**

The number and specific order in which each component of the System are to be assembled must be determined ahead of time. The depths of the desired monitoring zones and layers of backfill (where applicable) must be determined in advance of the installation. The design log will serve as a reference during the install. Ensure that an 'as built' installation log is maintained. See Appendix I for an example of a "Waterloo System Installation Log".

Before the install date, reconfirm that the borehole is still open to its target depth. Once the Waterloo System is received, make sure that the shipment looks complete and that nothing appears damaged. Contact Solinst immediately to resolve any issues before proceeding with the install.

If a Solinst Trainer is requested, the training will be completed in its entirety, prior to starting the installation. See Appendix IV for the Terms and Conditions of training.

The System weighs about 1 lbs/ft., which doesn't include the weight of the Packers. Therefore, at least two physically strong field assistants will be needed to lower the System by hand. If the depth to water is more than 30 m (100 ft.) below ground surface, then a hoisting winch (drilling rig) will be needed to assist with holding and lowering the System via an optional support cable.

#### **Tools and equipment you should bring for the installation:**

- Appropriate safety precautions and equipment to ensure a safe working environment at your site
- Water Level Meter/Well Depth Indicator
- Lights and/or security if the installation goes beyond daylight hours or more than 1 day is needed to complete the installation
- Plastic sheeting to keep the Waterloo casing, tubing, etc. clean when being laid out on the ground during installation
- Pylons or traffic cones for safety and to identify the lay down area or work zone
- Hand-spray water bottle used to lubricate pipe joints
- Two 5 gal pails
- One roll of black electrical tape to temporarily identify the ports and associated pump tube discharge ends
- 11/16" (18 mm) and 5/8" (16 mm) wrenches
- Hacksaw - to achieve desired System stick-up
- Large dowel or spindle
- Small piece of sand paper to assist in pushing tubing over the pump stems



**! NOTE**

A System about 30 m (100 ft.) below water will most likely require water added to the casing string during installation in order to counter System buoyancy (see Section 8.0).

When packers are used, the water inside the casing string should not exceed the static water level of the borehole during installation.

**! NOTE**

If not using a support cable, begin with the Base Plug near the borehole, and simply follow the design log to attach the components in sequence.

**! NOTE**

See Section 5.0 for joint connection instructions and Section 6.0 for connecting tubing and/or cabling to each Port.

## 4.0 Assembling the System

One person should be assigned as 'Team Leader' for the installation. This Team Leader is key in directing and ensuring that the components of the System are installed in the correct sequence. The Team Leader will keep an 'as built' record of the Multilevel System.

Arrange and group all of the equipment for each separate System near the borehole. Inventory and record each piece, as is proposed for the System on the Waterloo System Installation Field Log (see Appendix I for example).

Unpack the (optional) vibrating wire transducers (VWT) and soak them in water. Preferably submerge them in the borehole or in a bucket of water close in temperature to borehole groundwater. These need to stabilize prior to obtaining their individual 'zero value' (head/pressure) reading (see Section 6.2).

On the most suitable ground surface, measure off and mark a line out from the borehole 10% longer than the depth to the deepest Port. By example, if the deepest Port is at 30 m (100 ft.), measure off and make a reference mark at ~33 m (110 ft.). This is your initial reference for cutting tubing. If required, unroll a ~1 m (3 ft.) wide length of thin mil plastic (Visqueen) polysheeting to this mark.

If used, uncoil and lay out the support cable. The outstretched cable will likely be about 1.5 m (5 ft.) beyond the length of your plastic and reference mark.



**Figure 4-1 Plastic & SS Support Cable Laid Out**  
(Wood core boxes are used here to weigh down plastic)

To begin, attach the stainless steel Base Plug to the end of the support cable nearest the borehole. Following the sequence as set in your Installation Log, each component is walked to the far end of the plastic and threaded over the support cable, female joint end first, and walked back to the borehole for connection to the previous component. Section 5.0 discusses how to connect each joint.

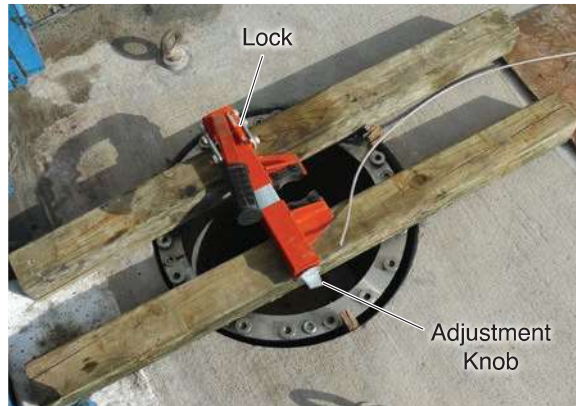

Figure 4-2 An Installation Clamp Over a Borehole



Figure 4-3 A Base Plug, Casing, Port, and Packer Section



Figure 4-4 Initial Section Being Installed Down-hole

When adding each Port to the sequence you will connect the monitoring tubing and/or transducer or pump to be used at that Port. Each successive component will be threaded over the support cable, as well as the monitoring tubing and cabling as it is added. Section 6.0 discusses Port connections.



Figure 4-5 Casing Section Being Threaded Over Monitoring Tubing

**!** **NOTE**

To use the installation clamp, slide the unlocking bar to the unlocked position and open the clamp by lifting the handle. Adjust the width of the jaws via the adjustment knob so the casing is held tightly when the clamp is closed. Return the locking bar to the locked position.

Once at least 1.5 m (5 ft.) of the System has been assembled, start lowering the System into the borehole. Adjust and lock the installation clamp onto this assembly to hold it in place. The System is now hanging in the borehole and supported by the installation clamp.

Continue to install the System in the sequence shown in your Log, making each connection as described in the following section. Be sure to record the components as they are assembled over the borehole on the Installation Log (see Appendix I).

## 5.0 Joint Connections

### Connecting Casing, Packers, & Ports



Figure 5-1 Packer and Casing Joint with Shear Tie

*Tools and accessories required:* needle nose pliers, Oetiker pliers, hand spray water bottle, shear ties.



Figure 5-2 Tools and Accessories Required

All joints are pushed / twisted together over the borehole while components are held in-place by the installation clamp or support cable. The male joint end of the component faces up and the female joint end faces downhole.

Spray the inside of the female and male ends of the components to be attached. The water spray serves to lightly lubricate the joint to make for an easier connection, as well as to reduce the risk of tearing the o-ring. When you are making this connection, be sure not to kink or pinch the monitoring tubes inside the Multilevel System.

Once the joint is coupled, push the shear tie through the shear window and around until it exits the same window. To help with this, needle nose pliers can be used to grab the tail of the shear tie. Lock and pull the shear tie tight. Use the Oetiker pliers to snip off the excess 'tail'.

#### **!** NOTE

Before threading component sections over the cables/tubing, feel inside the female joint end to ensure an o-ring is present.

#### **!** NOTE

DO NOT place the installation clamp on the Packers. Simply connect the next length of casing above the Packer. This next casing will be the hold point for the assembly.



Figure 5-3 Coupled Joint



Figure 5-4 Push Shear Tie Through the Window



Figure 5-5 Pull Shear Tie Tight



Figure 5-6 Cut Off the Excess Shear Tie



## 6.0 Port Connections

### 6.1 Attaching Open Tubes

Tools and accessories required: Oetiker pliers, tubing cutter, black electrical tape, rod/broom handle, sand paper.

#### NOTE

1/2"OD x 3/8"ID or 5/8"OD x 1/2"ID tubing can be used. The 1/2"OD tubing is clamped directly onto the Port Stem with an Oetiker #14 clamp, while the 5/8"OD tubing fits over a 8 cm (3") length of 1/2"OD tubing before being clamped to the Port Stem with an Oetiker #17 clamp.



Figure 6-1 Tools and Accessories Required

Beginning with the deepest Port (Port 1), stand at the borehole holding the spool of tubing (1/2"OD x 3/8"ID or 5/8"OD x 1/2"ID). A broom handle or equivalent pole works well to hold the spool. A second person will 'walk' the end of the tubing to the measured reference mark (Section 4.0). Once the tubing end is pulled to this reference mark, label the tube about 30 cm (1 ft.) from the tubing end. Black electrical tape works well. Use the black tape to wrap the number of bands corresponding to the Port number around the tubing end (i.e. 1 band of black tape represents Port 1). Cut the tubing at the spool.

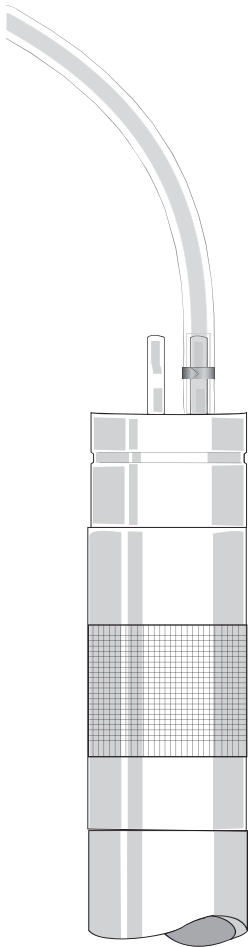

Figure 6-2 Tubing Being Pulled to Reference Mark

#### NOTE

Remember to label each tubing/cable end.

At the next Port, roll off the tubing to the end of the previous cut tubing length, and cut at this new reference mark. Use this reference for the remaining Ports, so as more Ports are added the tubing and cable ends will meet at the same point. Remember to label each length of tubing as you progress.



**Figure 6-3**  
5/8"OD x 1/2"ID tubing attached over  
8 cm (3") of 1/2"OD x 3/8"ID tubing  
to Port Stem Using Oetiker #17  
Clamp

Be sure there is a clean cut to the tubing end at the Port. Place one single ear Oetiker #14 clamp over the tubing and push the tubing end onto the stainless steel Port Stem. Using the Oetiker pliers, squeeze the clamp 'shoulders' together to securely attach the tubing to the stem.



**Figure 6-4** 1/2"OD x 3/8"ID tubing attached to Port Stem Using Oetiker #14 Clamp

**Note:** if using 5/8"OD tubing, a 8 cm (3") length of 1/2"OD tubing has to be first pushed onto the Port Stem. Then the 5/8"OD tubing is pushed over the 1/2"OD tubing and clamped to the Port Stem with an Oetiker #17 clamp (see Figure 6-3).

**6.2 Attaching Vibrating Wire Transducers (VWT)**

Tools and accessories required: 11/16" (18 mm) and 5/8" (16 mm) wrenches.



**Figure 6-5** Tools and Accessories Required

**! NOTE**

Match the serial number on the body of the VWT with the label at the end of the cable.

Each one of the VWT's cables has been cut to the length requested in the original order. This length also includes an additional 10% contingency. The total cable length is labeled on the cable's end.

Match the serial number on the VWT body with the labeled cable end, and its corresponding "Vibrating Wire Transducer Calibration Report" provided in the shipment (see Appendix II).



Figure 6-6 Presoaking the Vibrating Wire Transducers

**! NOTE**

Record the VWT 'zero value' on the Installation Log. It is needed to benchmark against all future readings.

Soak all of the VWTs for about 30 minutes, in either the borehole, or in a bucket of water at the same temperature as the borehole water. Once the VWT has stabilized, lift the VWT just out of the water and record the measured transducer temperature and vibration reading. Record this value on the Installation Log as the VWT's 'zero value'.

Compare this 'zero value' to the 'Factory Zero Reading' on the Calibration Report. These values should not differ by more than 0.1% of full scale. Remember that pressure varies with elevation (your site vs. factory calibration location), temperature, and barometric pressure.

The 'zero value' is used to subtract from all future pressure/head readings to calculate final depth to water measurements. See Appendix III for a sample depth to water calculation.

Uncoil the VWT's cable out to its full length. Push the 3/8" SS compression fitting with attached VWT onto the Port Stem. Using the 11/16" and 5/8" wrenches, tighten the two compression fitting nuts onto the Port Stem by 1 and 1/4 turns.



Figure 6-7 Vibrating Wire Transducer





Figure 6-8



Figure 6-9

## 6.3 Attaching a Pump (Bladder or Double Valve)

Tools and accessories required: tubing cutter, Oetiker pliers, Oetiker clamps, sand paper, 10 cm (4") of 1/2"OD x 3/8"ID tubing, black electrical tape, rod/broom handle.



Figure 6-10 Tools and Accessories Required

There are two stems on each pump. The shorter stem is the sample stem, which the sample line (white/natural) will be connected to. The longer stem is the drive gas stem, which the drive line will be connected to. Depending on whether you use LDPE or PTFE-lined, the drive line may be red colored or white/natural, respectively.



Figure 6-11 5/8"x6" Double Valve Pump

### ! NOTE

Use the black tape to wrap the number of bands corresponding to the Port number around the tubing end (i.e. 1 band of black tape represents Port 1).

Beginning with the deepest Port (Port 1), stand at the borehole holding the spool of tubing. A broom handle or equivalent pole works well to hold the spool.

Identify/label the end of this tubing by wrapping a 25 mm (1") piece of black electrical tape around the tubing to form a 'black band'. Let each band represent the Port number. Here, one band of the tape on the tubing end will represent that this tubing will be connected to Port 1. If using PTFE tubing, use a different colour tape to represent the drive line tubing.

A second person will 'walk' the end of the labelled tubing to the measured reference mark. Once the tubing end is pulled to this reference mark. Cut the tubing at the spool.

At the next Port, roll off the tubing to the end of the previous cut tubing length, and cut at this reference mark. Use this reference for the remaining Ports, so as more Ports are added, the tubing and cable ends will meet at the same point. Remember to label each length of tubing as you progress.

**! NOTE**

If you are using PTFE-lined tubing, be careful not to allow the PTFE lining to become separated and cause a visible 'bubble' at the Port Stem.

Make a clean fresh cut to both tubing ends at the borehole. Place one small double ear Oetiker clamp over each pump stem. Wrap a small piece of sandpaper around the tubing for 'traction' and push the sample tubing over the shorter pump stem. Use the sandpaper to help push the drive tubing over the longer pump stem. If you are using PTFE-lined tubing, be sure to check that the PTFE lining has not become separated from the tubing while pushing it onto the pump stem. If you see a 'bubble' through the tubing, pull it off the stem, make a fresh cut, and restart this step.



Figure 6-12 Using Sand Paper to Push Tubing onto Pump Stem

Using the Oetiker pliers, incrementally crimp both ears on each clamp. Alternate from one ear to the other, slowly pinching the ears closed. Repeat this cycle 2 or 3 times to achieve a proper crimp. Once the clamp is closed properly you should not be able to see light through the ears of the clamp.

Cut a piece of 1/2"OD x 3/8"ID tubing about 10 cm (4") long. Push this onto the Port Stem by about 5 cm (2"). Using the Oetiker pliers, crimp a #14 Oetiker clamp over the tubing, attaching it to the Port Stem.



Figure 6-13 Tubing Attached to Port Stem

Place another #14 Oetiker clamp over the open 1/2"OD x 3/8"ID tubing end. Push the pump intake into the tubing end. You will notice that the pump intake is recessed to receive the Oetiker clamp. Crimp the clamp to the pump.



Figure 6-14 Pump Connected to Port Stem

## **7.0 Testing Monitoring Equipment**

### **Before Packer Expansion or Backfilling**

Tools and accessories required:

For testing pumps: 466 Pump Controller, 466 Drive Line Adaptor to 1/4"OD tubing (push), drive gas.

For testing Vibrating Wire Transducers: VWT readout unit.

For testing open tubes: Water Level Meter, Peristaltic Pump.

With the Multilevel installed to depth, before adding water to activate the packers or backfilling the System, (if applicable) individually check and record VWT readings and pumping discharges to confirm proper connections, installation, and performance.



Figure 7-1 Testing Pumps and Transducers

**! NOTE**

After the addition of water, the Packers may take 1 - 3 days to expand. This primarily depends on the Head differential between the water in the borehole and the water in the System. A higher differential will put more pressure on the Packers, therefore expanding them more quickly.

**! NOTE**

Water is used to counter buoyancy and for 'sinking' the System during installation.

## 8.0 Packer Activation

### Adding Water

Tools and accessories required: water.

Depending on how many Packers are used, eventually your System will likely require water to counter buoyancy. As a rule of thumb, when the ratio of the total length of casing versus the depth to water is greater than 2:1, the System will float. For example, if the installed length of casing is 15 m (50 ft.) and the depth to water is 7.5 m (25 ft.), be ready to add water. Add just enough water to 'sink' the System. Do not overfill.

To activate the Packers for expansion you will need about 2.5 L/m (0.2 USgals/ft.) of clean water (Therefore, a 60 m (200 ft.) Waterloo System requires about 150 L (40 USgals) of water). Do not overfill the System, and remember to leave the water level in the PVC Casing below the frost line (if applicable). Repeated addition of small amounts of water may be required as the Packers inflate. The water level within the System, versus in the borehole, should not differ by more than 30 m (100 ft.).



Figure 8-1 Adding Water to the System



**NOTE**

Allow for at least 50 cm (20") of clearance above the final PVC Casing 'stick-up' and the underside of your protective outer enclosure. This will ensure that you do not pinch the monitoring tubes and cables above the completed manifold.

**NOTE**

Take a water level reading in the borehole and record it in the "Water Level at End" box on the Installation Log, after the System is installed to depth.

## 9.0 Wellhead Manifold Completion

### 9.1 Standard Option

Tools and accessories required: tubing cutter, Phillips screwdriver, PVC pipe saw/cutter.

Determine the desired 'stick-up' of PVC casing when the system is at its final depth. If applicable, cut the last piece of PVC Riser to the appropriate length and install the Riser Clamp to achieve your desired 'stick-up'. The Riser Clamp ensures that the proper stick-up is maintained when the System is hung. For safety, use a casing clamp and lower the System to depth. If you have used the SS support cable to lower the System, be sure to continue to use this cable to support the System during the packer expansion (up to three days).



Figure 9-1 Tubing Organized Around the Wellhead

Remove the two Phillips screws from the white protective housing of the Wellhead Manifold Base and then remove the Manifold Base from the 10 cm (4") diameter protective housing. Install this lower (black) portion of the Manifold (small end first) onto the completed installed PVC Casing. Using the numbered Wellhead as a guide, separate and organize the tubes and/or cables into a 'wagon wheel' pattern around the Wellhead.

Thread the open tubes, sample tubes (white) and/or blue VWT cables through the numbered Wellhead. Re-attach and screw the numbered Wellhead to the Manifold Housing at the Wellhead.



Figure 9-2 Tubing and Cables Installed Through a Wellhead

### 9.2 Multipurge Option

If pumps are used, follow the steps above, but before attaching the Wellhead, choose one drive line tube and hold it up against the 10 cm (4") diameter white protective housing which is at its final elevation at the wellhead. Trim the red drive line tube at a point about 5 cm (2") above the white protective housing. Insert this tubing end into the white (translucent) plastic compression fitting on the base of the numbered Wellhead. You should be able to see the red tubing pass through this fitting. Hand tighten the fitting. Repeat this procedure on the remaining drive tubes. Re-attach the numbered Wellhead to the Manifold Housing at the Wellhead and tighten the screws.



Figure 9-3 Pump Tubing Being Attached to a Wellhead

**9.3 Wellhead Protection**

Allow sufficient wellhead access when you install a protective cover over the well. Use a large well cover to allow plenty of room to access the wellhead. The following diagrams show some suggested completions for the 401 Multilevel System. These enclosures are not available at Solinst, however they are available from most drilling contractors.

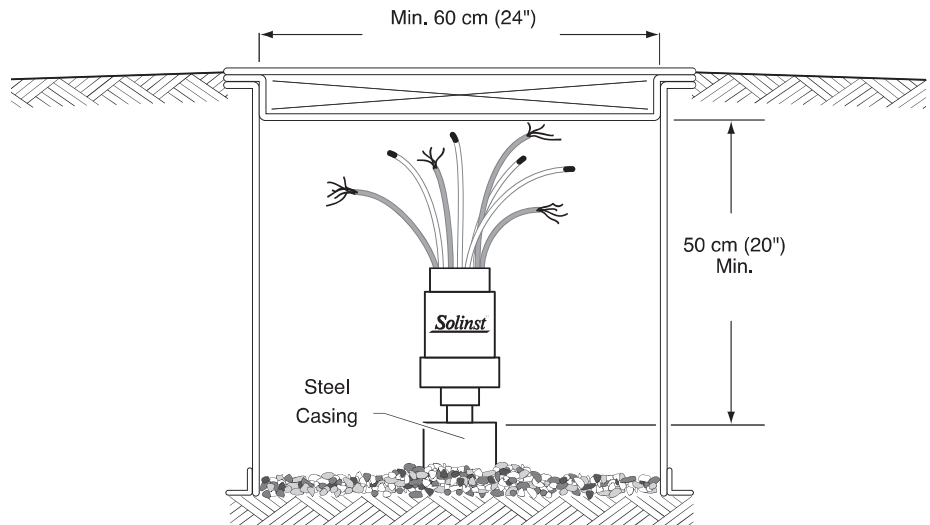

**Figure 9-4**  
Waterloo Multilevel Wellhead Inside Flushmount Vault

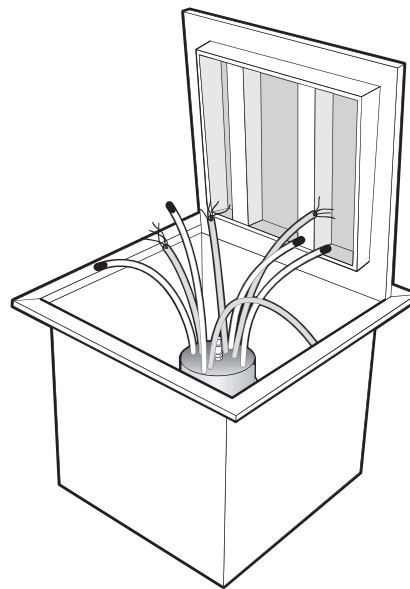

**Figure 9-5**  
Typical Road Box or Vault



**Figure 9-6**  
Above ground completion  
Minimum 15 cm (6") dia. and  
50 cm (20") clearance is required



## 10.0 Monitoring Options

Water levels and samples can be accurately obtained using the following high quality Solinst instruments:

### Water Level Measurement

#### Model 102 Water Level Meter

The narrow cable Model 102 Water Level Meter and 102M Mini Water Level Meter with a 4 mm (0.157") diameter P4 Probe can be used to monitor water levels in open tubes. The coaxial cable is accurately laser marked every mm or 1/100 ft.



### Well Completion

#### Model 103 Tag Line

The Tag Line is ideal to aid accurate placement of sand and bentonite during borehole completion.



### Sampling Methods

Depending on the depth to water at your site, and your sampling protocol, Solinst offers various sampling options.

#### **Model 410 Peristaltic Pump**

Ideal for sample retrieval from shallow water levels less than 9 m (30 ft.).



#### **Model 408M (3/8" Dia.) Micro Double Valve Pump**

The Small and flexible design makes this gas drive pump ideal for delivering high quality samples, in combination with the Model 464 Electronic Control Unit. Flow rates of 20 to 150 mL/min make the 408M suitable for low flow sampling applications. Constructed of stainless steel and PTFE tubing for any depths up to 73 m (240 ft.) applications. This is the only viable option in wells with depth to water over 45m (150 ft.).



#### **Model 464 Electronic Control Unit**

Durable & easy to operate with the 408M by using the presets and fine tuning capabilities built into the Solinst Model 464 Electronic Control Unit.



#### **Mini Inertial Pump**

This Mechanical pump uses 1/4" LDPE tubing. Typical flow rates of 50 to 250 ml/min. Suitable for use to depths of approximately 45 m (150 ft.). If the water level on your site is deeper than 15 m (50 ft), PTFE tubing is recommended.





48 Spencer St. Lebanon, N.H. 03766 USA

## Vibrating Wire Pressure Transducer Calibration Report

Type: A Date of Calibration: June 16, 2006  
 Serial Number: 06-5822 Temperature: 24.1 °C  
 Pressure Range: 170 kPa †Barometric Pressure: 993.9 mbar  
 Cal. Std. Cntrl. #(s): W9-181, 529, 511, 506, 069, 309, 428, 028 Calibration Instruction: VW Pressure Transducers Rev:B  
 Technician: *J. Quilley*

Applied Pressure (kPa)	Gage Reading 1st Cycle	Gage Reading 2nd Cycle	Average Gage Reading	Calculated Pressure (Linear)	Error Linear (%FS)	Calculated Pressure (Polynomial)	Error Polynomial (%FS)
0.0	9971	9973	9972	0.211	0.12	0.030	0.02
34.0	9270	9271	9271	34.00	0.00	34.07	0.04
68.0	8568	8570	8569	67.79	-0.12	68.02	0.01
102.0	7862	7863	7863	101.8	-0.11	102.0	0.02
136.0	7153	7155	7154	135.9	-0.03	136.0	0.02
170.0	6442	6442	6442	170.2	0.14	170.0	0.00

(kPa) Linear Gage Factor (G): 0.04817 (kPa/ digit) Regression Zero: 9976  
 Polynomial Gage Factors: A: -1.389E-07 B: -0.04589 C: 471.37  
 Thermal Factor (K): 0.07278 (kPa/ °C)

(psi) Linear Gage Factor (G): 0.006986 (psi/ digit)  
 Polynomial Gage Factors: A: -2.01522E-08 B: -0.006655 C: 68.366  
 Thermal Factor (K): 0.010557 (psi/ °C)

Calculated Pressures: Linear,  $P = G(R_0 - R_1) + K(T_1 - T_0) - (S_1 - S_0)**$   
 Polynomial,  $P = AR_1^2 + BR_1 + C + K(T_1 - T_0) - (S_1 - S_0)**$

†Barometric pressures are absolute. Barometric compensation is not required with vented and differential pressure transducers.

### Factory Zero Reading:

GK-401 Pos. B or F(R<sub>0</sub>): 9978 Temp(T<sub>0</sub>): 25.9 °C †Baro(S<sub>0</sub>): 989.0 mbar Date: August 04, 2006

\*Initial zero readings must be established in the field following the procedures described in the Instruction Manual. If the Polynomial equation is used the field value of C must be calculated by plugging the initial zero reading into the polynomial equation with the value of P set to zero.

The above instrument was found to be in tolerance in all operating ranges.  
 The above named instrument has been calibrated by comparison with standards traceable to the NIST, in compliance with ANSI Z540-1

This report shall not be reproduced except in full without written permission of Geokon Inc.



### Sample Calculation

#### Converting a VWT reading from the GK-404 to a depth to water

In our example, let's assume the VWT is connected to a monitoring port that is located at a depth of 100 ft (30.48 m) below ground surface.

From the GK-404 readout:

Zero Reading (pre installation) of VWT: 9978 digits

Submerged Reading of VWT: 7978 digits

Difference between Zero Reading & Submerged Reading: 2000 digits

From the "Vibrating Wire Pressure Transducer Calibration Report" (sample in Appendix III), locate the "Linear Gage Factor" for each specific transducer serial number. In our example:

**(kPa) Linear Gage Factor (G): 0.04817 (kPa/ digit)**

**(psi) Linear Gage Factor (G): 0.006986 (psi/ digit)**

To calculate the pressure head (psi or kPa) on the VWT, multiply the appropriate "Linear Gage Factor", by the difference between the zero reading and submerged reading. From our example:

$0.006986 \text{ (psi/digit)} \times 2000 \text{ digits} = 13.972 \text{ psi (96.33 kPa)}$

Therefore, VWT serial number 06-5822 has a pressure head of 13.972 psi (96.33 kPa).

To calculate the depth to water, simply convert psi (kPa) to feet (meters):

$13.972 \text{ psi} \times 2.307 \text{ foot of head/psi} = 32.23 \text{ feet of head.}$

$96.33 \text{ kPa} \times 0.1020 \text{ meter of head/kPa} = 9.826 \text{ meters of head}$

Now subtract the depth to the Port inlet (100ft/30.48m) from the pressure head.

$100 \text{ ft} - 32.23 \text{ feet of head} = 67.77 \text{ ft.}$

$30.48 \text{ m} - 9.826 \text{ meters of head} = 20.65 \text{ m}$

**Terms and Conditions**  
**for Waterloo or CMT® System Multilevel Installation Training**  
**An Understanding of Responsibility**

Solinst Canada Ltd. (Solinst) offers installation training only, which includes providing verbal and 'by example' instruction of proper methods of assembling Waterloo or CMT Multilevel Systems. Actual installation of a Solinst Multilevel System is the sole responsibility of the Customer. Solinst cannot offer guidance, nor recommend the location of a monitoring zone, nor advise on the backfilling of the System to achieve the monitoring zones your site requires.

Based on the information that you provide, Solinst may assist with determining sufficient quantities of components to construct your Multilevel System(s), however Solinst assumes no responsibility for the chemical and physical compatibility of materials, initial design or on-site layout design, in-field design changes, or the condition of the borehole(s).

All equipment received by the client for use in their installations must be inspected upon receipt, and any deficiencies noted and reported to Solinst immediately.

Solinst, at its sole discretion, reserves the right to assess the cause and liability of any System fault or equipment failure at the time of receipt, during assembly, or following installation. If the defect is determined to be caused by inadequate materials or workmanship, excluding actual installation procedures – which are the Customer's responsibility – Solinst will, at its own discretion, replace or refund the cost of the failed component. Solinst is not liable for any contingent costs which may arise from the installation for any reason including the loss of use of any part of the System(s) or borehole(s).

The undersigned understands and accepts the above terms and conditions:

Company: \_\_\_\_\_ Signature: \_\_\_\_\_

Name: \_\_\_\_\_ Date: \_\_\_\_\_