

ClimaVUE™ 50

Compact Digital Weather Sensor



Limited Warranty

“Products manufactured by CSI are warranted by CSI to be free from defects in materials and workmanship under normal use and service for twelve months from the date of shipment unless otherwise specified in the corresponding product manual. (Product manuals are available for review online at www.campbellsci.com.) Products not manufactured by CSI, but that are resold by CSI, are warranted only to the limits extended by the original manufacturer. Batteries, fine-wire thermocouples, desiccant, and other consumables have no warranty. CSI’s obligation under this warranty is limited to repairing or replacing (at CSI’s option) defective Products, which shall be the sole and exclusive remedy under this warranty. The Customer assumes all costs of removing, reinstalling, and shipping defective Products to CSI. CSI will return such Products by surface carrier prepaid within the continental United States of America. To all other locations, CSI will return such Products best way CIP (port of entry) per Incoterms ® 2010. This warranty shall not apply to any Products which have been subjected to modification, misuse, neglect, improper service, accidents of nature, or shipping damage. This warranty is in lieu of all other warranties, expressed or implied. The warranty for installation services performed by CSI such as programming to customer specifications, electrical connections to Products manufactured by CSI, and Product specific training, is part of CSI's product warranty. **CSI EXPRESSLY DISCLAIMS AND EXCLUDES ANY IMPLIED WARRANTIES OF MERCHANTABILITY OR FITNESS FOR A PARTICULAR PURPOSE. CSI hereby disclaims, to the fullest extent allowed by applicable law, any and all warranties and conditions with respect to the Products, whether express, implied or statutory, other than those expressly provided herein.**”

Assistance

Products may not be returned without prior authorization. The following contact information is for US and international customers residing in countries served by Campbell Scientific, Inc. directly. Affiliate companies handle repairs for customers within their territories. Please visit www.campbellsci.com to determine which Campbell Scientific company serves your country.

To obtain a Returned Materials Authorization (RMA) number, contact CAMPBELL SCIENTIFIC, INC., phone (435) 227-9000. Please write the issued RMA number clearly on the outside of the shipping container. Campbell Scientific's shipping address is:

CAMPBELL SCIENTIFIC, INC.

RMA# _____
815 West 1800 North
Logan, Utah 84321-1784

For all returns, the customer must fill out a "Statement of Product Cleanliness and Decontamination" form and comply with the requirements specified in it. The form is available from our website at www.campbellsci.com/repair. A completed form must be either emailed to repair@campbellsci.com or faxed to (435) 227-9106. Campbell Scientific is unable to process any returns until we receive this form. If the form is not received within three days of product receipt or is incomplete, the product will be returned to the customer at the customer's expense. Campbell Scientific reserves the right to refuse service on products that were exposed to contaminants that may cause health or safety concerns for our employees.

Safety

DANGER — MANY HAZARDS ARE ASSOCIATED WITH INSTALLING, USING, MAINTAINING, AND WORKING ON OR AROUND TRIPODS, TOWERS, AND ANY ATTACHMENTS TO TRIPODS AND TOWERS SUCH AS SENSORS, CROSSARMS, ENCLOSURES, ANTENNAS, ETC. FAILURE TO PROPERLY AND COMPLETELY ASSEMBLE, INSTALL, OPERATE, USE, AND MAINTAIN TRIPODS, TOWERS, AND ATTACHMENTS, AND FAILURE TO HEED WARNINGS, INCREASES THE RISK OF DEATH, ACCIDENT, SERIOUS INJURY, PROPERTY DAMAGE, AND PRODUCT FAILURE. TAKE ALL REASONABLE PRECAUTIONS TO AVOID THESE HAZARDS. CHECK WITH YOUR ORGANIZATION'S SAFETY COORDINATOR (OR POLICY) FOR PROCEDURES AND REQUIRED PROTECTIVE EQUIPMENT PRIOR TO PERFORMING ANY WORK.

Use tripods, towers, and attachments to tripods and towers only for purposes for which they are designed. Do not exceed design limits. Be familiar and comply with all instructions provided in product manuals. Manuals are available at www.campbellsci.com or by telephoning (435) 227-9000 (USA). You are responsible for conformance with governing codes and regulations, including safety regulations, and the integrity and location of structures or land to which towers, tripods, and any attachments are attached. Installation sites should be evaluated and approved by a qualified engineer. If questions or concerns arise regarding installation, use, or maintenance of tripods, towers, attachments, or electrical connections, consult with a licensed and qualified engineer or electrician.

General

- Prior to performing site or installation work, obtain required approvals and permits. Comply with all governing structure-height regulations, such as those of the FAA in the USA.
- Use only qualified personnel for installation, use, and maintenance of tripods and towers, and any attachments to tripods and towers. The use of licensed and qualified contractors is highly recommended.
- Read all applicable instructions carefully and understand procedures thoroughly before beginning work.
- Wear a **hardhat** and **eye protection**, and take **other appropriate safety precautions** while working on or around tripods and towers.
- **Do not climb** tripods or towers at any time, and prohibit climbing by other persons. Take reasonable precautions to secure tripod and tower sites from trespassers.
- Use only manufacturer recommended parts, materials, and tools.

Utility and Electrical

- **You can be killed** or sustain serious bodily injury if the tripod, tower, or attachments you are installing, constructing, using, or maintaining, or a tool, stake, or anchor, come in **contact with overhead or underground utility lines**.
- Maintain a distance of at least one-and-one-half times structure height, 20 feet, or the distance required by applicable law, **whichever is greater**, between overhead utility lines and the structure (tripod, tower, attachments, or tools).
- Prior to performing site or installation work, inform all utility companies and have all underground utilities marked.
- Comply with all electrical codes. Electrical equipment and related grounding devices should be installed by a licensed and qualified electrician.

Elevated Work and Weather

- Exercise extreme caution when performing elevated work.
- Use appropriate equipment and safety practices.
- During installation and maintenance, keep tower and tripod sites clear of un-trained or non-essential personnel. Take precautions to prevent elevated tools and objects from dropping.
- Do not perform any work in inclement weather, including wind, rain, snow, lightning, etc.

Maintenance

- Periodically (at least yearly) check for wear and damage, including corrosion, stress cracks, frayed cables, loose cable clamps, cable tightness, etc. and take necessary corrective actions.
- Periodically (at least yearly) check electrical ground connections.

WHILE EVERY ATTEMPT IS MADE TO EMBODY THE HIGHEST DEGREE OF SAFETY IN ALL CAMPBELL SCIENTIFIC PRODUCTS, THE CUSTOMER ASSUMES ALL RISK FROM ANY INJURY RESULTING FROM IMPROPER INSTALLATION, USE, OR MAINTENANCE OF TRIPODS, TOWERS, OR ATTACHMENTS TO TRIPODS AND TOWERS SUCH AS SENSORS, CROSSARMS, ENCLOSURES, ANTENNAS, ETC.

Table of Contents

PDF viewers: These page numbers refer to the printed version of this document. Use the PDF reader bookmarks tab for links to specific sections.

1. Introduction	1
2. Precautions	1
3. Initial Inspection	2
4. QuickStart	2
5. Overview	5
5.1 Drip Counter Rain Gage	6
5.2 Pyranometer.....	6
5.3 Anemometer	6
5.4 Relative Humidity Sensor.....	6
5.5 Thermistor	6
5.6 Tilt Sensor	7
5.7 Barometric Pressure Sensor.....	7
5.8 Lightning Sensor.....	7
6. Specifications	7
7. Installation	9
7.1 Siting	9
7.2 Mounting	9
7.2.1 Required Tools	10
7.2.2 Mounting Procedure	10
7.2.3 Optional Bird-Spike Kit	12
7.3 Wiring to the Data Logger	14
7.4 Programming	15
7.4.1 CRBasic Programming.....	15
8. Operation	16
8.1 Sensor Measurements	16
8.1.1 Measurements at Fast Scan Rates.....	18
8.2 Snow and Ice Accumulation.....	18
8.3 Heavy Rain and Strong Wind.....	18
8.4 Correcting Pressure to Sea Level.....	19
9. Troubleshooting and Maintenance	19
9.1 Maintenance and Calibration.....	19
9.2 Troubleshooting.....	23

Appendices

A. Importing Short Cut Code Into CRBasic Editor....	A-1
B. Example Program	B-1
C. Determining True North and Sensor Orientation .	C-1
D. SDI-12 Sensor Support.....	D-1
D.1 Introduction	D-1
D.2 SDI-12 Command Basics	D-1
D.2.1 Acknowledge Active Command (a!).....	D-2
D.2.2 Send Identification Command (aI!).....	D-2
D.2.3 Address Query Command (?!).....	D-2
D.2.4 Change Address Command (aAb!).....	D-2
D.2.5 Start Measurement Commands (aM!)	D-3
D.2.6 Start Concurrent Measurement Commands (aC!)	D-3
D.2.7 Stopping a Measurement Command.....	D-5
D.2.8 Send Data Command (aD0! ... aD7!)	D-5
D.2.9 Continuous Measurement Command (aR7!).....	D-5
D.2.10 Extended Commands.....	D-5
D.3 SDI-12 Transparent Mode	D-6
D.3.1 Changing an SDI-12 Address	D-6
D.4 References	D-7

Figures

7-1. ClimaVUE50, MetSENS, or WindSonic Mounting Pipe Kit and crossarm	10
7-2. ClimaVUE 50 mounted to a pole with V-bolt and nuts.....	10
7-3. Engraved N on the ClimaVUE 50	11
7-4. Bubble level on the ClimaVUE 50	11
7-5. ClimaVUE 50 with connector cable.....	12
7-6. Spikes inserted into the plastic ring slots.....	13
7-7. Bird-spike kit mounted properly.....	14
9-1. Temperature sensor and ultrasonic transducer openings	20
9-2. Top view of ClimaVUE 50.....	20
9-3. Sintered glass reflection plate and splash guard	21
9-4. Teflon screen	21
9-5. Rain gage cutout.....	23
C-1. Magnetic declination for the contiguous United States (2015).....	C-1
C-2. Declination angles east of True North are subtracted from 360 to get True North.....	C-2
C-3. Declination angles west of True North are added to 0 to get True North	C-2

Tables

6-1. Measurement Specifications.....	8
7-1. Wire Color, Function, and Data Logger Connection.....	14
8-1. ClimaVUE 50 SDI-12 Commands	16
D-1. ClimaVUE 50 SDI-12 Command and Response Set.....	D-1
D-2. Example aM! Sequence	D-3

D-3. Example aC! Sequence D-4
D-4. ClimaVUE 50 Extended Commands D-6

CRBasic Example

B-1. CR1000X Program Measuring the ClimaVUE 50..... B-1

ClimaVUE™ 50 Compact Digital Weather Sensor

1. Introduction

The ClimaVUE™50 is an affordable all-in-one meteorological sensor that fulfills your common weather monitoring needs with simplicity when paired with the flexible and scalable Campbell Scientific data-acquisition platforms. This sensor uses the SDI-12 serial protocol to report air temperature, relative humidity, vapor pressure, barometric pressure, wind (speed, gust, and direction), solar radiation, precipitation, and lightning strike (count and distance). It does this with no moving parts, while consuming little power. A built-in tilt sensor indicates when the mounting mast has tilted. This diverse product is great for quick deployment, for remote locations, to fill gaps in large networks, as part of a more complex system, or if you just need something simple.

NOTE

This manual provides information only for CRBasic data loggers. For retired Edlog data logger support, contact Campbell Scientific.

2. Precautions

- READ AND UNDERSTAND the *Safety* section at the front of this manual.
- Care should be taken when opening the shipping package to not damage or cut the cable jacket. If damage to the cable is suspected, consult with a Campbell Scientific support and implementation engineer.
- The ClimaVUE 50 is a precision instrument. Please handle it with care.
- To avoid shock or damage to the instrument, never apply power while wiring.
- Ensure that the ClimaVUE 50 is properly wired to the data logger before applying power. Applying power when incorrectly wired could damage the ClimaVUE 50 beyond repair.
- When mounting the ClimaVUE 50 to the mast, do not over-tighten the V-bolt as it will cause the plastic to break.
- The ClimaVUE 50 must be mounted within 2 degrees of level on a mast that will not tilt in the wind for the rain sensor to work. The built-in bubble level and the internal tilt sensor can be used during installation to level the ClimaVUE 50 to within these specifications. Recording and monitoring the tilt sensor readings can spot when the sensor is no longer level. Refer to Section 5.6, *Tilt Sensor* (p. 7), and Section 7.2.2, *Mounting Procedure* (p. 10), for more information.
- Routine maintenance is essential for accurate rainfall measurements. Debris blocking the inlet (funnel, spring, downspout, and flared hole) can result in under reporting of rainfall. Debris blocking the downspout screen can result in over reporting of rainfall.

- When attaching the extension cable to the ClimaVUE 50 cable, only hand tighten the connectors. Using tools to tighten the connectors can permanently weld the stainless steel connectors together.
- When cleaning or handling, avoid more than light pressure on the sonic transducers.
- When cleaning, do not immerse the sensor in water and do not touch the temperature sensor needle.
- Before integrating the ClimaVUE 50 into a system, make sure to follow the recommended installation instructions and have the proper protections in place to safeguard sensors from damage.
- This non-heated sensor is not suitable for solid precipitation or riming environments (Section 8.2, *Snow and Ice Accumulation* (p. 18)).
- Heavy rains and strong winds can temporarily affect the accuracy of the measurements (Section 8.3, *Heavy Rain and Strong Wind* (p. 18)).

3. Initial Inspection

Upon receipt of the ClimaVUE 50, inspect the packaging and contents for damage. File damage claims with the shipping company.

4. QuickStart

A video that describes data logger programming using *Short Cut* is available at: www.campbellsci.com/videos/cr1000x-datalogger-getting-started-program-part-3. *Short Cut* is an easy way to program the data logger to measure the sensor and assign data logger wiring terminals. *Short Cut* is available as a download on www.campbellsci.com. It is included in installations of *LoggerNet*, *PC200W*, *PC400*, or *RTDAQ*.

The following procedure also shows using *Short Cut* to program the ClimaVUE 50.

1. Open *Short Cut* and click **Create New Program**.
2. Double-click the data logger model.

- In the **Available Sensors and Devices** box, type ClimaVUE or locate the sensor in the **Sensors | Meteorological | Basic Weather** folder. Double-click **ClimaVUE 50**.

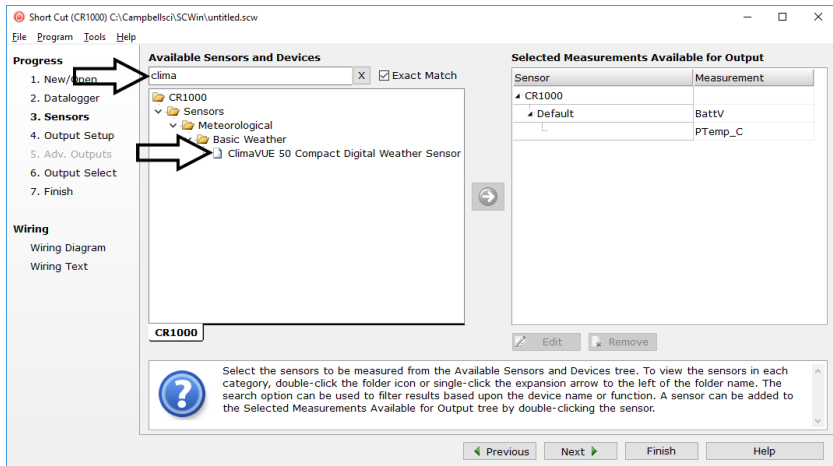

- Type the correct **SDI-12 Address** (default is zero). Type the elevation of the site in the same units as the **Site elevation units**. Default units are meters, which can be changed by clicking on the **Site elevation units** box and selecting **Feet**.

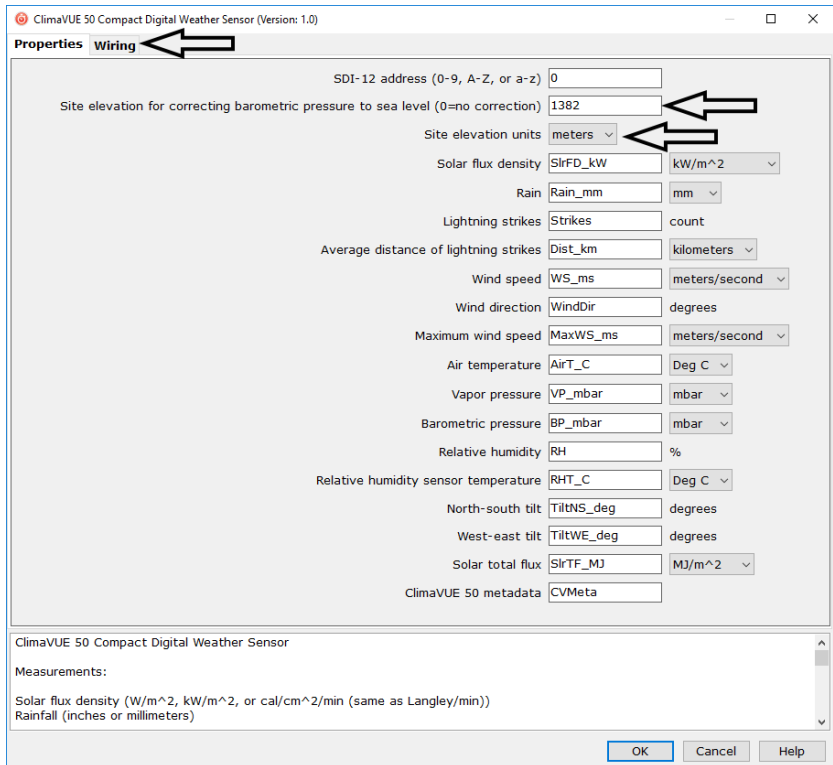

- Click on the **Wiring** tab to see how the sensor is to be wired to the data logger. If measuring additional SDI-12 sensors and an unused control terminal is available on the data logger, click on the control terminal (C) and change it to an unused control terminal, then use the ClimaVUE 50 factory default address of 0 for the SDI-12 address. If an unused control terminal is not available, type a new SDI-12 address in the **SDI-12 address** box, then change the SDI-12 address in the ClimaVUE 50 (Appendix D.2.4, *Change Address Command (aAb!) (p. D-2)*). Click **OK** after wiring the sensor.

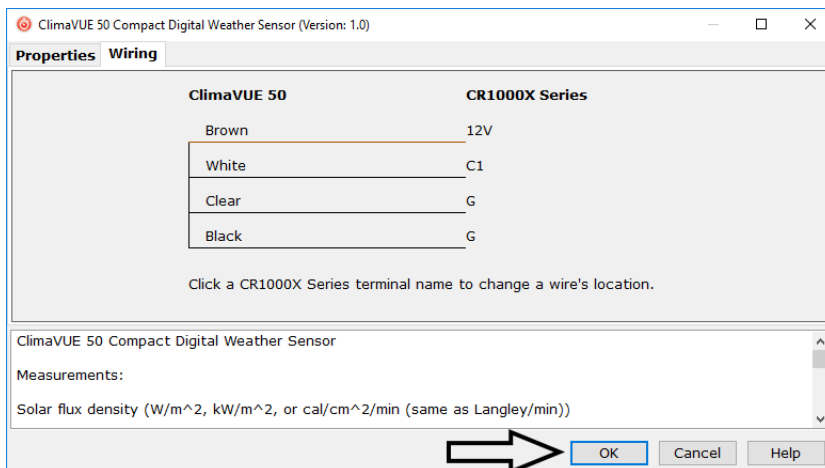

- In **Output Setup**, type the scan rate (60 seconds recommended), meaningful table names, and **Data Output Storage Interval**. Click **Next**.

NOTE

If your scan rate is longer than 10 seconds (s), the ClimaVUE 50 will be measured every scan. If it's less than 10 s, the ClimaVUE 50 will be measured every 10 s and your scan rate must be evenly divisible into 10 s.

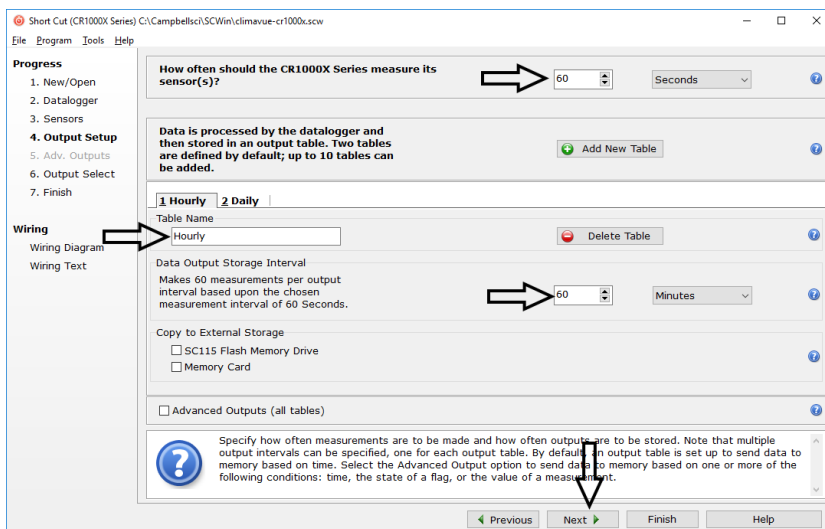

7. Select the measurement and its associated output option.

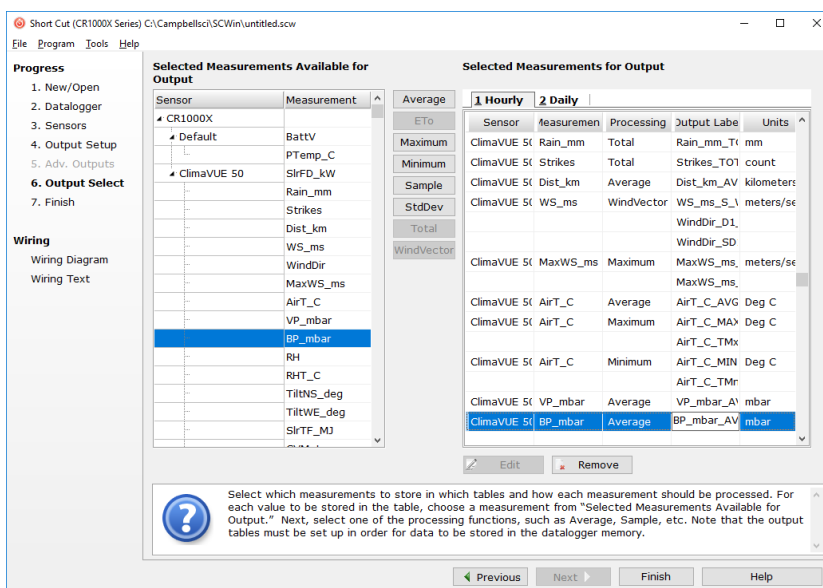

8. Click **Finish** and save the program. Send the program to the data logger if the data logger is connected to the computer.
9. Connect the sensor to the data logger, check the output of the sensor in the data display in *LoggerNet*, *PC400*, *RTDAQ*, or *PC200W* to make sure it is making reasonable measurements.

5. Overview

All sensors are integrated into a single, small form-factor unit, requiring minimal installation effort. With a robust, no-moving-parts design that prevents errors because of wear or fouling, the ClimaVUE 50 is ideal for long-term, remote installations.

Upon power up, the ClimaVUE 50 initializes an internal timer to 55. This internal timer is incremented by 1 every second and resets to 0 after incrementing to 59. In addition, issuing an averaging command (**M!**, **R0!**, **R3!**, **R7!**, and **C!**) resets this timer to 55.

While powered up, the ClimaVUE 50 takes solar radiation, precipitation, wind, and air temperature measurements every 10 s at internal time intervals of 0, 10, 20, 30, 40, and 50 s, then logs the values internally. By default, tilt, atmospheric pressure, relative humidity, and the temperature of the RH sensor are measured every 60 s at the internal timer interval of 4 s, and logged internally. Vapor pressure is computed from the relative humidity and air temperature every 60 s and logged internally.

The **R7!** command will force the instantaneous return of all the previous parameters, but must be used at intervals of 10 s or greater. When **R7!** is executed at a 10 s rate, the sensor returns samples. When the **R7!** or other SDI-12 measurement commands are issued slower than two times their default measurement interval, the sensor returns averages, accumulations, or maximums of the values it logged internally. It then resets its internal averaging counters and

accumulators. Hence, oversampling is not necessary. Less frequent sampling decreases power consumption. For example, 10 s polling frequency requires 1 mA current compared to 0.4 mA at the recommended polling frequency of 60 s. The ClimaVUE 50 has two error codes available—general error code –9999 and invalid wind measurement error code –9990.

5.1 Drip Counter Rain Gage

The ClimaVUE 50 has a 9.31-cm diameter rain-collection funnel. A spring in the funnel acts as a filter to keep out large particles while allowing enough flow so water does not back up. Rain collected by the funnel exits the funnel through a precision flared hole that forms the rain into drops of a known size. The falling drops hit and momentarily bridge the gap between two gold pins, creating an electrical pulse.

The ClimaVUE 50 counts the pulses (drops) and calculates the water volume.

5.2 Pyranometer

A silicon-cell pyranometer integrated into the lip of the rain gage funnel measures total incoming (direct and diffuse) solar radiation. The pyranometer has a cosine-corrected head to ensure accurate readings regardless of sun angle. Accurate solar radiation measurements require the sensor to be level and clean.

5.3 Anemometer

An ultrasonic anemometer underneath the rain gage measures wind speed. Two pairs of orthogonally oriented transducers emit ultrasonic signals that bounce off the porous sintered glass plate and back up to the opposite sensor. The ClimaVUE 50 calculates wind speed by measuring differences in the time it takes for sound to travel back and forth between the transducers.

5.4 Relative Humidity Sensor

The relative humidity sensor is located behind the circular Teflon® screen in the same housing as the sonic transducers. The screen protects the sensor from liquid water and dust while allowing water vapor to freely pass to the sensor. The sensor measures relative humidity and temperature of the cavity, then uses those measurements to calculate vapor pressure. Vapor pressure doesn't change with temperature but relative humidity does. Because the true air temperature (measured by the thermistor needle and corrected using wind and solar measurements) differs from the cavity temperature, the true relative humidity is computed using the true air temperature and the calculated vapor pressure.

5.5 Thermistor

A small stainless steel needle containing a thermistor extends from the middle of the four sonic transducers in the center of the anemometer. The thermistor sits in open air. Instead of using a radiation shield to prevent solar loading, the temperature measurement is corrected by an energy balance equation that uses solar radiation and wind speed measurements. The equation calculates the true air temperature based on the solar load on the needle and the convective cooling of the thermistor to an accuracy of ± 0.6 °C. Compare this error to the combined temperature and radiation shield errors of competitive units. For more information, refer to the [ClimaVUE™50—Correction of air temperature](#)

measurements from a radiation-exposed sensor White Paper available at:
www.campbellsci.com/app-notes.

5.6 Tilt Sensor

After initial leveling with a small level or the built-in bubble level, the internal tilt sensor helps users keep the ClimaVUE 50 level. Regularly check the X and Y tilt data. Adjust the ClimaVUE 50 leveling if it has tilted. More than two degrees off level can cause errors in the rain and solar radiation measurements. Although this tilt sensor may be used to level the instrument, it is much easier to use the small bubble level on the bottom of the anemometer plate.

The tilt sensor is an accelerometer that reads whatever acceleration it is experiencing. Under static conditions, this is the gravitational acceleration, and therefore provides an accurate indication of tilt. However, when the sensor is moving, for example due to wind-caused vibration on the mount, the tilt sensor measures a combination of gravity and vibration.

5.7 Barometric Pressure Sensor

The barometric pressure sensor is located behind the Teflon screen next to the relative humidity sensor on the same circuit board. It measures the atmospheric pressure in the range of 500 to 1100 hPa.

5.8 Lightning Sensor

The lightning sensor uses AM radio signals, which are disrupted by lightning. Circuitry inside the sensor detects disrupted AM signal. The ClimaVUE 50 records the time of the disruption and determines strike distance based on the intensity of the signal.

6. Specifications

Features:

- All the common meteorological measurements with one simple digital (SDI-12) output
- Less than 1 mA average current at 12 VDC consumption making it ideal for solar-powered sites
- Integrated tilt sensor helps assure that the sensor stays level over time
- No sensor configuration required
- Compact design for quick, low impact installation
- Low maintenance—no moving parts significantly reduces maintenance cost and time
- Detachable cable from sensor for fast sensor swap / servicing
- Compatible with Campbell Scientific CRBasic data loggers: CR300 series, CR6 series, CR800 series, CR1000, and CR1000X series

TABLE 6-1. Measurement Specifications

Measurement	Range	Resolution	Accuracy or Repeatability
Air Temperature	-50 to 60 °C	0.1 °C	±0.6 °C
Vapor Pressure	0 to 47 kPa	0.01 kPa	Varies with temperature and humidity, ±0.2 kPa typical below 40 °C. A table listing accuracies for different temperature and humidity values is available at: www.metergroup.com/environment/products/atmos-41-weather-station
Relative Humidity	0 to 100%	0.1	varies with temperature and humidity, ±3% RH typical
Barometric Pressure	500 to 1100 hPa	0.1 hPa	±1 hPa (-10 to 50 °C); ±5 hPa (-40 to 60 °C)
Wind Speed	0 to 30 m s ⁻¹	0.01 m s ⁻¹	0.3 m s ⁻¹ or 3%, whichever is greater
Wind Speed Max – 10 s Gust	0 to 30 m s ⁻¹	0.1 m s ⁻¹	0.3 m s ⁻¹ or 3%, whichever is greater
Wind Direction	0 to 359°	1°	±5°
Solar Radiation	0 to 1750 W m ⁻²	1 W m ⁻²	±5% of measurement typical
Precipitation	0 to 400 mm hr ⁻¹	0.017 mm	±5% of measurement from 0 to 50 mm hr ⁻¹
Tilt	0 to 180°	0.1°	±1°
Lightning Strike Count	0 to 65535 strikes	1 strike	variable with distance, >25% detection at <10 km, typical
Lightning Average Distance	0 to 40 km	3 km	variable

Output:	SDI-12 Version 1.3 compliant
Operating Temperature Range:	-50 to 60 °C (except barometer and RH, which are -40 to 60 °C)
Supply Voltage:	3.6 to 15.0 VDC (continuous)
Power Consumption	
Quiescent:	0.3 mA
Maximum Peak Current:	33 mA
Average:	1.0 mA (using R7! every 10 s), 0.4 mA (using R7! every 60 s or slower)
Digital Voltage (logic high):	2.8 V (minimum), 3.0 V (typical), 5.5 V (maximum)
Digital Voltage (logic low):	-0.3 V (minimum), 0.0 V (typical), 0.8 V (maximum)
Measurement Duration:	110 ms (typical), 3000 ms (maximum)

Diameter (includes rain gage filter):	10 cm (4 in)
Height:	34 cm (13.4 in)
Application of Council Directive	
2011/65/EU:	Restrictions of Substances Directive (RoHs2)
2014/30/EU:	Electromagnetic Compatibility Directive (EMC)
Standards to Which Conformity is Declared	
EN 61326-1:2013:	Electrical equipment for measurement, control and laboratory use—EMC requirements—for use in industrial locations
EN 50581:2012:	Technical documentation for the assessment of electrical and electronic product with respect to the restriction of hazardous substances
EU Declaration of Conformity:	View at: www.campbellsci.com/climavue-50
Power Line Slew Rate:	1.0 V/ms (use an oscilloscope to measure the voltage at the power input to the sensor as it is turned on to ensure it is supplying 1 V per millisecond or faster)

7. Installation

If you are programming the data logger with *Short Cut*, skip Section 7.3, *Wiring to the Data Logger* (p. 14), and Section 7.4, *Programming* (p. 15). *Short Cut* does this work for you. See Section 4, *QuickStart* (p. 2), for a *Short Cut* tutorial.

7.1 Siting

Locate the sensor away from obstructions such as trees and buildings. The horizontal distance from an obstruction should be at least ten times the height of the obstruction. If mounting the sensor on the roof of a building, the height of the sensor above the roof, should be at least 1.5 times the height of the building.

Ensure that the solar radiation sensor is not shaded.

7.2 Mounting

The ClimaVUE 50 includes a V-bolt for mounting to a pipe with a nominal outer diameter of 31.8 to 50.8 mm (1.25 to 2.0 in). The CM310 mounting pole is recommended to mount the ClimaVUE 50 with a small enclosure and solar panel (no other sensors). The ClimaVUE 50 can mount to a crossarm by using the ClimaVUE50, MetSENS, or WindSonic Mounting Pipe Kit, which includes a mounting tube and a CM220 Right Angle Mounting Kit (includes bracket, two U-bolts, and four nuts).

7.2.1 Required Tools

1/2-in open-end wrench
Torpedo level
UV-resistant cable ties
Compass
Ladder

7.2.2 Mounting Procedure

1. If using a crossarm, attach the mounting tube to the crossarm by using the CM220 Right Angle Mounting Kit, then mount the crossarm to the tripod or tower (FIGURE 7-1).

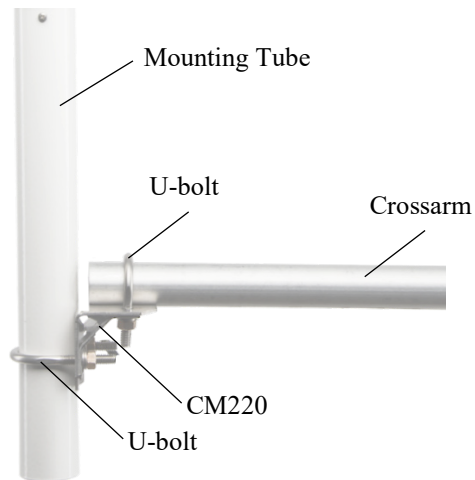

FIGURE 7-1. ClimaVUE50, MetSENS, or WindSonic Mounting Pipe Kit and crossarm

2. Loosely mount the ClimaVUE 50 to the tripod mast, CM300-series pole, or mounting tube by using the V-bolt, washers, and nuts (FIGURE 7-2).



FIGURE 7-2. ClimaVUE 50 mounted to a pole with V-bolt and nuts

3. Orient the ClimaVUE 50 so that the engraved **N** points to True North (FIGURE 7-3). Appendix C, *Determining True North and Sensor Orientation* (p. C-1), contains detailed information on determining True North using a compass and the magnetic declination for the site.



FIGURE 7-3. Engraved N on the ClimaVUE 50

4. Use a torpedo level or the bubble level underneath the sensor to level it (FIGURE 7-4). The angle of the instrument mount may need to be adjusted if the mast is not vertical. Shims can be added between the top of the mast and the bottom of the ClimaVUE 50 to achieve level. The sensor must be within $\pm 2^\circ$ of dead level (0, 0) in both the X and Y directions to accurately measure rainfall and solar radiation. The $\pm 2^\circ$ can be confirmed by viewing the Tilt x and Tilt y orientation values returned by the **R7!** command.

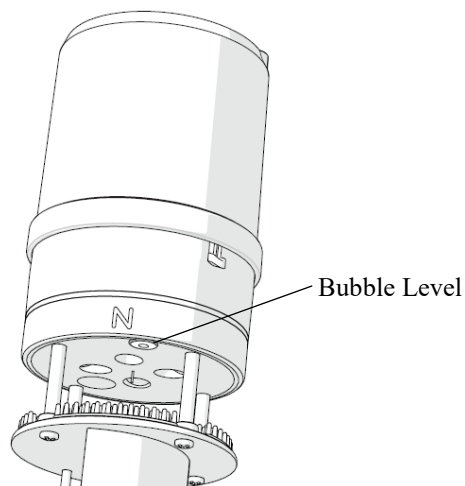

FIGURE 7-4. Bubble level on the ClimaVUE 50

5. Once level, tighten the V-bolt nuts by hand until hand-tight, then gently tighten with a wrench and recheck the level (FIGURE 7-5).

CAUTION Do not over-tighten V-bolt as it will cause the plastic to break.



FIGURE 7-5. ClimaVUE 50 with connector cable

6. Mate the extension cable connector to the cable connector shown in FIGURE 7-5. Only hand tighten the connectors.

CAUTION Hand tighten only! Using tools to tighten the connectors can permanently weld the stainless steel connectors together.

7. Route the cable down the pole to the instrument enclosure.
8. Secure the cable to the crossarm (if applicable) and tripod or pole by using cable ties.

7.2.3 Optional Bird-Spike Kit

The optional bird-spike kit helps discourage birds from roosting on the ClimaVUE 50. The kit consists of a plastic ring with flexible spikes. When installed, the spikes point upwards and extend 10.2 cm (4 in) above the funnel. Their shape and location minimize interference with rain and solar measurements. The spikes are designed not to hurt the birds.

The plastic ring includes secondary spike positions that can be drilled by the user to install additional short spikes. The additional spikes are to be provided by the user.

Items included in kit:

- (13) Spikes (includes one spare)
- (1) Spike ring

Required tools (not included):

- (1) Pliers

Bird-spike kit installation procedure:

1. Count all parts to ensure nothing was lost in shipping.
2. Gently press a bird spike into a slot on the bird spike ring by hand.
3. Using pliers, pinch the bird spike near its base and press down until it is fully seated.
4. Repeat steps 2 and 3 for all bird spikes (FIGURE 7-6).



FIGURE 7-6. Spikes inserted into the plastic ring slots

5. Tug upward on each spike to make sure the spike is pressed in.
6. Position the ring on top of the ClimaVUE 50 with the pyranometer between two spikes (FIGURE 7-7); this will limit spike shadows on the sensor.

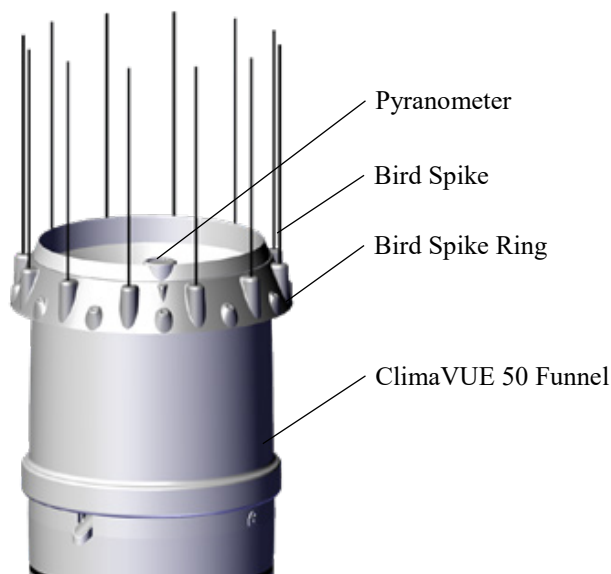

FIGURE 7-7. Bird-spike kit mounted properly

7. Press finished bird deterrent onto the ClimaVUE 50 funnel to at least the depth shown in FIGURE 7-7.

NOTE You can bend the spikes to minimize the shadow on the pyranometer.

7.3 Wiring to the Data Logger

CAUTION To avoid shock or damage to the instrument, never apply power while wiring.

CAUTION Ensure that the ClimaVUE 50 is properly wired to the data logger before applying power. Applying power when incorrectly wired could damage the ClimaVUE 50 beyond repair.

Connect the ClimaVUE 50 to the data logger in the order shown in TABLE 7-1.

TABLE 7-1. Wire Color, Function, and Data Logger Connection		
Wire Color	Wire Function	Data Logger Connection
White	SDI-12 Signal	C ¹ or U configured for SDI-12 ¹
Clear	Shield	⏏ (analog ground)
Brown	Power	12V
Black	Power Ground	G

¹ C and U terminals are automatically configured by the measurement instruction.

If multiple SDI-12 sensors are connected to a data logger, Campbell Scientific recommends using separate terminals when possible. However, multiple SDI-12 sensors or multiple ClimaVUE 50 sensors can connect to the same data logger control or U terminal. Each must have a unique SDI-12 address. Valid addresses are 0 through 9, a through z, and A through Z. The ClimaVUE 50 ships with a default SDI-12 address of 0.

For the CR6 and CR1000X, triggering conflicts may occur when a companion terminal is used for a triggering instruction such as **TimerInput()**, **PulseCount()**, or **WaitDigTrig()**. For example, if the ClimaVUE 50 is connected to C3 on a CR1000X, C4 cannot be used in the **TimerInput()**, **PulseCount()**, or **WaitDigTrig()** instructions.

7.4 Programming

Short Cut is the best source for up-to-date data logger programming code. If your data acquisition requirements are simple, you can probably create and maintain a data logger program exclusively with *Short Cut*. If your data acquisition needs are more complex, the files that *Short Cut* creates are a great source for programming code to start a new program or add to an existing custom program.

NOTE

Short Cut cannot edit programs after they are imported and edited in *CRBasic Editor*.

A *Short Cut* tutorial is available in Section 4, *QuickStart* (p. 2). If you wish to import *Short Cut* code into *CRBasic Editor* to create or add to a customized program, follow the procedure in Appendix A, *Importing Short Cut Code Into CRBasic Editor* (p. A-1). Programming basics for *CRBasic* data loggers are provided in the following section. Appendix B, *Example Program* (p. B-1), provides a complete *CRBasic* program that measures the ClimaVUE 50.

7.4.1 CRBasic Programming

The **SDI12Recorder()** instruction is used to measure the ClimaVUE 50 sensor. This instruction sends a request to the sensor to make a measurement and then retrieves the measurement from the sensor. See Section 8.1, *Sensor Measurements* (p. 16), for more information.

For most data loggers, the **SDI12Recorder()** instruction has the following syntax:

```
SDI12Recorder(Destination, SDIPort, SDIAddress, "SDICommand",
Multiplier, Offset, FillNAN, WaitonTimeout)
```

For the **SDIAddress**, alphabetical characters need to be enclosed in quotes (for example, "A"). Also enclose the **SDICommand** in quotes as shown. The **Destination** parameter must be an array. The required number of values in the array depends on the command (TABLE 8-1).

FillNAN and **WaitonTimeout** are optional parameters (refer to *CRBasic Help* for more information).

8. Operation

8.1 Sensor Measurements

The ClimaVUE 50 responds to the SDI-12 commands shown in TABLE 8-1. When using an **M!**, **M1!**, or **M3!** command, the data logger waits for the time specified by the sensor, sends the **D!** command, pauses its operation, and waits until either it receives the data from the sensor or the sensor timeout expires. If the data logger receives no response, it will send the command a total of three times, with three retries for each attempt, or until a response is received. Because of the delays this command requires, it is only recommended in measurement scans of 10 seconds or more.

A **C!** command follows the same pattern as an **M!** command with the exception that it does not require the data logger to pause its operation until the values are ready. Rather, the data logger picks up the data with the **D!** command on the next pass through the program. Another measurement request is then sent so that data is ready on the next scan.

The **R7!** command directly reads the sensor measurements and outputs all of its values.

NOTE

This section briefly describes using the SDI-12 commands. For additional SDI-12 information, refer to Appendix D, SDI-12 Sensor Support (p. D-1), www.sdi-12.org, or the videos [SDI-12 Sensors | Watch or Sniffer Mode](#) and [SDI-12 Sensors | Transparent Mode](#).

SDI-12 command (<i>a</i> is the sensor address)	Values Returned	Units
<i>a</i> R7! ^{2,3}	<ol style="list-style-type: none"> 1. Solar flux density 2. Precipitation 3. Lightning strike count 4. Strike distance 5. Wind speed 6. Wind direction 7. Wind speed max. – 10 s gust 8. Air temperature 9. Vapor pressure 10. Barometric pressure (absolute) 11. Relative humidity 12. Humidity sensor temperature 13. Tilt x orientation 14. Tilt y orientation 	<ol style="list-style-type: none"> 1. W m^{-2} 2. mm 3. km 4. m s^{-1} 5. ° 6. m s^{-1} 7. °C 8. kPa 9. kPa 10. fraction (0 to 1) 11. °C 12. ° 13. °

TABLE 8-1. ClimaVUE 50 SDI-12 Commands¹

SDI-12 command (<i>a</i> is the sensor address)	Values Returned	Units
<i>aM!</i> ²	<ol style="list-style-type: none"> 1. Solar flux density 2. Precipitation 3. Lightning strike count 4. Wind speed 5. Wind direction 6. Wind speed max. – 10 s gust 7. Air temperature 8. Vapor pressure 9. Barometric pressure (absolute) 	$W\ m^{-2}$ mm $m\ s^{-1}$ ° $m\ s^{-1}$ °C kPa kPa
<i>aM1!</i> ²	<ol style="list-style-type: none"> 1. Tilt x orientation 2. Tilt y orientation 3. Compass heading (disabled) 	° ° °
<i>aM3!</i> ²	<ol style="list-style-type: none"> 1. Strike distance 2. Relative humidity 3. Humidity sensor temperature 4. Tilt x orientation 5. Tilt y orientation 6. Compass heading (disabled) 7. North wind speed 8. East wind speed 9. Wind speed max. – 10 s gust 	km fraction (0 to 1) °C ° ° ° $m\ s^{-1}$ $m\ s^{-1}$ $m\ s^{-1}$
<i>aC!</i> ²	<ol style="list-style-type: none"> 1. Solar flux density 2. Precipitation 3. Lightning strike count 4. Strike distance 5. Wind speed 6. Wind direction 7. Maximum wind speed 8. Air temperature 9. Vapor pressure 10. Barometric pressure (absolute) 11. Relative humidity 12. Humidity sensor temperature 13. Tilt x orientation 14. Tilt y orientation 15. Compass heading (disabled) 16. North wind speed 17. East wind speed 18. Wind speed max. – 10 s gust 	$W\ m^{-2}$ mm km $m\ s^{-1}$ ° $m\ s^{-1}$ °C kPa kPa fraction (0 to 1) °C ° ° $m\ s^{-1}$ $m\ s^{-1}$ $m\ s^{-1}$

TABLE 8-1. ClimaVUE 50 SDI-12 Commands¹

SDI-12 command (<i>a</i> is the sensor address)	Values Returned	Units
<i>aI!</i>	<i>a</i> 13CAMPBELLCLIM50 <i>xxx</i> VUE- <i>yyyyyyyy</i> Where: <i>a</i> = SDI-12 address <i>xxx</i> = OS version VUE- <i>yyyyyyyy</i> = the serial number	
<i>aAb!</i>	<i>b</i> Where: <i>b</i> = a new SDI-12 address	
?!	SDI-12 Address	
¹ Extended commands are included in Appendix D.2.10, <i>Extended Commands (p. D-5)</i> . ² The aR7! , aM! , aM1! , aM3! , and aC! commands reset the internal averaging, totalizing, and maximizing processes. ³ The aR7! command resets the internal averaging, totalizing, and maximizing processes. To allow enough time to internally initiate all measurements, this command only takes a measurement if 10 s have passed between the commands. If a new measurement has not been taken, the sensor returns the last reported value, except for the lightning strike count, which is interrupt based.		

See Appendix D, *SDI-12 Sensor Support (p. D-1)*, for additional commands and details of the SDI-12 protocol.

8.1.1 Measurements at Fast Scan Rates

Using the **SlowSequence** function allows the SDI-12 instruction to run as a background process, causing minimum interference to other measurements that use the analog hardware. Measuring the sensor in a **SlowSequence** section of the program allows faster programs to run as the main scan. However, if the data logger is too busy to complete all of its tasks, some slow sequence commands may be skipped resulting in NANs instead of measurements.

8.2 Snow and Ice Accumulation

The ClimaVUE 50 is not heated, so it will not measure frozen precipitation until snow and ice that have accumulated in the funnel melt. In locations with heavy snowfall or long periods below freezing, snow accumulation will fill the funnel and no longer accumulate, leading to inaccurate precipitation measurements even when the precipitation melts. Accumulation of snow, ice, or frost also adversely affects the accuracy of the solar radiation measurement and can compromise the wind measurements if accumulation occurs in the anemometer acoustic pathway or on the acoustic mirror.

8.3 Heavy Rain and Strong Wind

During strong storms, water can splash off of the horizontal bottom plate of the anemometer envelope and interrupt the signal passing between the sonic

transducers. The spikes on the bottom plate help dissipate the rainwater to minimize splashing and reduce the likelihood that the wind measurements are interrupted. Additionally, porous polyethylene membranes protect the ultrasonic transducers from direct splashing and the sintered (porous) glass construction draws water from the upper surface of the acoustic mirror to keep a constant sound path length. Despite these features, heavy rain and strong winds can cause water to reach the membranes and also cause temporary water buildup on the acoustic mirror. The hydrophobic nature of the transducer protective membranes and the quick-draining ability of the acoustic mirror should limit wind measurement interruptions to heavy rain and should bring wind measurement back online soon after extreme conditions abate.

8.4 Correcting Pressure to Sea Level

The weather service, most airports, radio stations, and television stations adjust the atmospheric pressure to a common reference (sea level). Equation 1 can be used to find the difference in pressure between the sea level and the site in kPa. That value (dP) is then added to the absolute pressure measurement returned by the ClimaVUE 50 as seen in the example program. Once that is done, the program shows the pressure conversion to hPa. U. S. Standard Atmosphere and dry air were assumed when Equation 1 was derived (Wallace, J. M. and P. V. Hobbes, 1977: *Atmospheric Science: An Introductory Survey*, Academic Press, pp. 59-61).

$$dP = 101.325 \left\{ 1 - \left(1 - \frac{E}{44307.69231} \right)^{5.25328} \right\} \quad (1)$$

The value dP is in kPa and the site elevation, E , is in meters. Add dP value to the offset in the measurement instruction.

Use Equation (2) to convert feet to meters.

$$E(m) = \frac{E(ft)}{3.281ft/m} \quad (2)$$

The corrections involved can be significant. For example, at 100 kPa and 20 °C, barometric pressure will decrease by 0.11 kPa for every 10 m increase in altitude.

9. Troubleshooting and Maintenance

NOTE

All factory repairs and recalibrations require a returned material authorization (RMA) and completion of the “Declaration of Hazardous Material and Decontamination” form. Refer to the [Assistance](#) page at the beginning of this manual for more information.

9.1 Maintenance and Calibration

Sensor maintenance should be performed at regular intervals, depending on the desired accuracy and the conditions of use.

1. Remove cobwebs, leaves, bird droppings, wasp nests, or other debris from the temperature sensor (FIGURE 9-1), ultrasonic transducer openings

(FIGURE 9-1), rain gage funnel (FIGURE 9-2), pyranometer (FIGURE 9-2), and sintered glass reflection plate (FIGURE 9-3).

CAUTION

Do not touch the temperature sensor when cleaning because it is very delicate and can be damaged if pushed into the body.

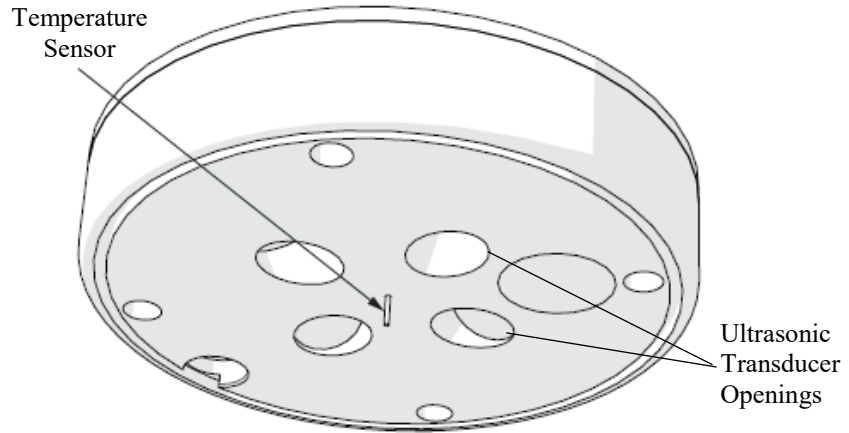

FIGURE 9-1. Temperature sensor and ultrasonic transducer openings

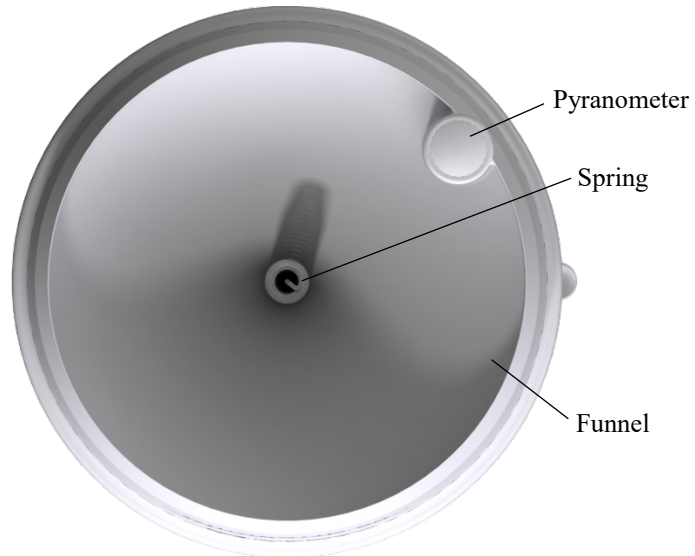

FIGURE 9-2. Top view of ClimaVUE 50



FIGURE 9-3. Sintered glass reflection plate and splash guard

2. Scrub the body with light to medium pressure using a warm, damp cloth.

CAUTION

Gently clean the sonic transducers and do not allow water to enter the ultrasonic sensors (FIGURE 9-1). Water may corrode the metal parts inside the sensors and ruin them.

3. Clean around posts and between crevices using a dry brush.
4. Inspect the Teflon screen (FIGURE 9-4) and replace if dirty.

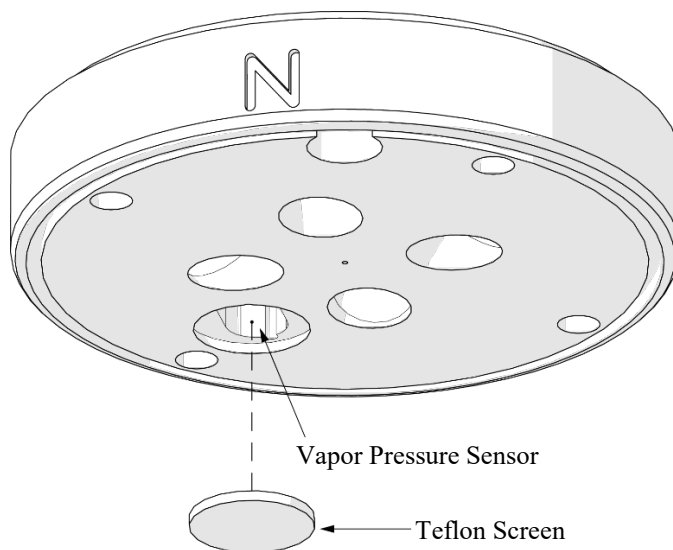

FIGURE 9-4. Teflon screen

5. Rain gage maintenance. Routine maintenance is essential for accurate rainfall measurements. Debris blocking the inlet (funnel, spring, downspout, and flared hole) can result in under reporting of rainfall. Debris blocking the downspout screen can result in over reporting of rainfall. The funnel locks in place using two pegs on the side of the funnel. To access the inside of the rain gage:
 - a. Press the funnel down against the spring and turn counter clockwise.
 - b. If necessary, unplug the pyranometer and remove funnel.

CAUTION

The pyranometer must be unplugged before fully removing the funnel.

- c. Check the downspout for debris (FIGURE 9-5). Use a pipe cleaner or small soft brush to clean the downspout.
- d. If needed, clean the spring after twisting it loose. Ensure that the gold electrodes are free of debris and contamination.
- e. Reattach the pyranometer connector.
- f. Check to be sure the downspout screen is clean and in place on the water exit downspout. If this screen gets plugged with debris, water can back up to the drip counting gold electrodes causing extra counts that can more than double the recorded rain. The screen keeps bugs out of the interior of the sensor.
- g. Replace the funnel by lining up the lock/unlock label located on the side of the funnel with the notch on the interface plate.
- h. Press the funnel down against the spring and turn clockwise until it clicks in place.
- i. Check the level of the ClimaVUE 50 (either with a torpedo level, bubble level, or the built-in tilt sensor).

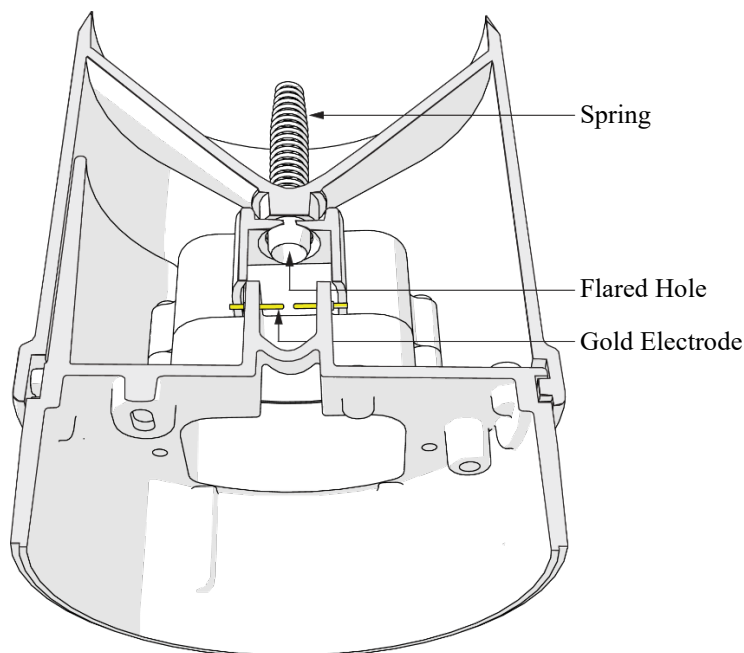

FIGURE 9-5. Rain gage cutout

A field-replaceable module contains the barometric pressure and relative humidity sensors. This module is under the Teflon screen (FIGURE 9-4) and should be replaced every two years. Calibrate or replace the pyranometer every two years. The pyranometer calibration number needs to be changed when the funnel containing the pyranometer is replaced. Campbell Scientific will send a calibration certificate listing the new number with the recalibrated or replaced pyranometer. An extended SDI-12 command is used to replace the calibration number (Appendix D.2.10, *Extended Commands* (p. D-5)). Contact Campbell Scientific for more information.

9.2 Troubleshooting

Symptom: NAN readings. NAN readings indicate the data logger isn't receiving data from the ClimaVUE 50.

1. Check that the sensor is wired to the control or U terminal specified by the **SDI12Recorder()** instruction.
2. Check the voltage to the sensor with a digital voltage meter. If a switched 12V terminal is used and programmed using CRBasic (not *Short Cut*), temporarily connect the red wire to a 12V terminal (non-switched) for test purposes.
3. Verify the probe SDI-12 address matches the address entered for the **SDI12Recorder()** instruction. The address can be verified or changed with the commands described in Appendix D, *SDI-12 Sensor Support* (p. D-1).

Symptom: Not reading any rain

1. Remove debris from rain gage (see step 5 in Section 9.1, *Maintenance and Calibration* (p. 19)).

2. Check the sensor level. The ClimaVUE 50 must be within approximately ± 2 degrees of dead level (0, 0) in both the X and Y directions to accurately measure rainfall. If not within this range, drops from the flared hole can miss the gold electrodes entirely. Use a torpedo level, the bubble level, or the internal tilt measurements to confirm that the ClimaVUE 50 is level.

Symptom: No wind speed (–9,990, –9,999 or –7999)

1. Check anemometer pathway to ensure debris is not blocking the path of the sonic transducer measurement (between transducers and acoustic mirror on base).
2. Check the sonic transducers for water build-up. Use a dry cloth to remove moisture.
3. Check to see that the sintered glass plate (FIGURE 9-3) is not dirty.
4. Clean by flushing with water and dry with a dry cloth.
5. Ensure that the ClimaVUE 50 is level.

Symptom: No temperature reading

1. Check the temperature needle to be sure it is not pushed in, which will break the thermistor wires.

CAUTION

Always gently handle the temperature sensor needle. It has delicate wires that can be easily damaged.

Appendix A. Importing Short Cut Code Into CRBasic Editor

This tutorial shows:

- Importing a *Short Cut* program into a program editor for additional refinement
- Importing a wiring diagram from *Short Cut* into the comments of a custom program

Short Cut creates files, which can be imported into *CRBasic Editor*. Assuming defaults were used when *Short Cut* was installed, these files reside in the C:\campbellsci\SCWin folder:

- .DEF (wiring and memory usage information)
- .CR300 (CR300-series data logger code)
- .CR6 (CR6-series data logger code)
- .CR8 (CR800-series data logger code)
- .CR1 (CR1000 data logger code)
- .CR1X (CR1000X-series data logger code)
- .CR3 (CR3000 data logger code)

Import *Short Cut* code and wiring diagram into *CRBasic Editor*:

1. Create the *Short Cut* program following the procedure in Section 4, *QuickStart* (p. 2). Finish the program. On the **Advanced** tab, click the **CRBasic Editor** button. The program opens in CRBasic with the name **noname.CR_**. Provide a name and save the program.

NOTE

Once the file is edited with *CRBasic Editor*, *Short Cut* can no longer be used to edit the program it created.

2. The program can now be edited, saved, and sent to the data logger.
3. Import wiring information to the program by opening the associated .DEF file. By default, it is saved in the c:\campbellsci\SCWin folder. Copy and paste the section beginning with heading “–Wiring for CRXXX–” into the CRBasic program, usually at the head of the file. After pasting, edit the information such that an apostrophe (') begins each line. This character instructs the data logger compiler to ignore the line when compiling. You can highlight several lines of CRBasic code then right-click and select **Comment Block**. (This feature is demonstrated at about 5:10 in the [CRBasic | Features](#) video.)

Appendix B. Example Program

The example program uses the **R7!** SDI-12 command to retrieve data. The barometric pressure measurement is adjusted to sea level. This adjustment assumes the site elevation is 1382 m, and a different value is required for sites at a different elevation (Section 8.4, *Correcting Pressure to Sea Level* (p. 19)). The adjustment is entered as a constant in the beginning of the program.

This program also includes instructions that set wind measurements that are less than 0 to the last valid measurements. These instructions are needed because high winds with rain can temporarily interfere with sonic wind measurements causing outputs of -9999 or -9990.

CRBasic Example B-1. CR1000X Program Measuring the ClimaVUE 50

```
'CR1000X Series

'Declare Constants
'The constant 15.29091 is for adjusting the barometric pressure measurement to sea level. This
'value is for a site altitude of 1382 m.
Cont SeaLevelAdj=15.29091

'Declare Variables and Units
Public BattV
Public PTemp_C
Public CVData(14)
Public SlrTF_MJ
Public CVMeta As String * 40
Public WSprev
Public WindDirprev
Public MaxWSprev
Public Invalid_Wind As Long

Alias CVData(1)=SlrFD_kw
Alias CVData(2)=Rain_mm
Alias CVData(3)=Strikes
Alias CVData(4)=Dist_km
Alias CVData(5)=WS_ms
Alias CVData(6)=WindDir
Alias CVData(7)=MaxWS_ms
Alias CVData(8)=AirT_C
Alias CVData(9)=VP_hPa
Alias CVData(10)=BP_hPa
Alias CVData(11)=RH
Alias CVData(12)=RHT_C
Alias CVData(13)=TiltNS_deg
Alias CVData(14)=TiltWE_deg

Units BattV=Volts
Units PTemp_C=Deg C
Units SlrTF_MJ=MJ/m^2
Units SlrFD_kw=kW/m^2
Units Rain_mm=mm
Units Strikes=count
Units Dist_km=kilometers
Units WS_ms=meters/second
Units WindDir=degrees
Units MaxWS_ms=meters/second
Units AirT_C=Deg C
Units VP_hPa=hPa
Units BP_hPa=hPa
Units RH=%
Units RHT_C=Deg C
```

```

Units TiltNS_deg=degrees
Units TiltWE_deg=degrees

'Define Data Tables
DataTable(Hourly,True,-1)
  DataInterval(0,60,Min,10)
  Average(1,SlrFD_kW,FP2,False)
  Totalize(1,SlrTF_MJ,IEEE4,False)
  Totalize(1,Rain_mm,FP2,False)
  WindVector(1,WS_ms,WindDir,FP2,False,0,0,0)
  FieldNames("WS_ms_S_WVT,WindDir_D1_WVT,WindDir_SD1_WVT")
  Maximum(1,MaxWS_ms,FP2,False,True)
  Totalize(1,Invalid_Wind,FP2,False)
  Average(1,AirT_C,FP2,False)
  Maximum(1,AirT_C,FP2,False,True)
  Minimum(1,AirT_C,FP2,False,True)
  Average(1,VP_hPa,IEEE4,False)
  Sample(1,BP_hPa,IEEE4)
  Maximum(1,BP_hPa,IEEE4,False,True)
  Minimum(1,BP_hPa,IEEE4,False,True)
  Sample(1,RH,FP2)
  Average(1,RHT_C,FP2,False)
  Average(1,TiltNS_deg,FP2,False)
  Average(1,TiltWE_deg,FP2,False)
  Totalize(1,Strikes,FP2,False)
  Minimum(1,Dist_km,FP2,False,True)
  Sample(1,CVMeta,String)
EndTable

DataTable(Daily,True,-1)
  DataInterval(0,1440,Min,10)
  Minimum(1,BattV,FP2,False,False)
  Totalize(1,Rain_mm,FP2,False)
  Average(1,SlrFD_kW,FP2,False)
  Totalize(1,SlrTF_MJ,IEEE4,False)
  WindVector(1,WS_ms,WindDir,FP2,False,0,0,1)
  Totalize(1,Invalid_Wind,FP2,False)
  FieldNames("WS_ms_S_WVT,WindDir_D1_WVT")
  Maximum(1,MaxWS_ms,FP2,False,True)
  Average(1,AirT_C,FP2,False)
  Maximum(1,AirT_C,FP2,False,True)
  Minimum(1,AirT_C,FP2,False,True)
  Average(1,VP_hPa,IEEE4,False)
  Maximum(1,BP_hPa,IEEE4,False,True)
  Minimum(1,BP_hPa,IEEE4,False,True)
  Maximum(1,RH,FP2,False,False)
  Minimum(1,RH,FP2,False,False)
  Maximum(1,RHT_C,FP2,False,False)
  Minimum(1,RHT_C,FP2,False,False)
  Maximum(1,TiltNS_deg,FP2,False,True)
  Minimum(1,TiltNS_deg,FP2,False,True)
  Maximum(1,TiltWE_deg,FP2,False,True)
  Minimum(1,TiltWE_deg,FP2,False,False)
  Sample(1,CVMeta,String)
EndTable

'Main Program
BeginProg
  'Main Scan
  WSprev = 0
  WindDirprev = 0
  MaxWSprev = 0
  Invalid_Wind = False
  Scan(60,Sec,1,0)
  'Default CR1000X Data Logger Battery Voltage measurement 'BattV'
  Battery(BattV)
  'Default CR1000X Data Logger Wiring Panel Temperature measurement 'PTemp_C'
  PanelTemp(PTemp_C,60)

```

```

'Get ClimaVUE 50 Compact Digital Weather Sensor metadata 'CVMeta' every day at midnight in
'case sensor is swapped or OS is updated
If TimeIntoInterval(0,1,Day) Then
  SDI12Recorder(CVMeta,C1,0,"I!",1,0)
EndIf
'ClimaVUE 50 Compact Digital Weather Sensor measurements
'SlrFD_kw', 'Rain_mm', 'Strikes', 'Dist_km', 'WS_ms', 'WindDir',
'MaxWS_ms', 'AirT_C', 'VP_hPa', BP_hPa', 'RH', 'RHT_C',
'TiltNS_deg', and 'TiltWE_deg'
'Get data from ClimaVUE 50 Compact Digital Weather Sensor
SDI12Recorder(CVData(),C1,0,"R7!",1,0,-1)
'High winds with rain can temporarily interfere with sonic wind measurements causing the
'sensor to output invalid winds of -9999 OR -9990.
'The following instructions set all wind measurements less than 0 to the previous valid
'wind measurements. This will "flat-line" the measurements until the sensor is able to
'make good readings again. The Invalid_Wind variable will be set to 1 when a wind
'measurement is invalid. For troubleshooting purposes, it is highly recommended that you
'Totalize the Invalid_Wind variable in any output tables you define that include wind
'speed AND/OR direction data from the ClimaVUE 50.
If WS_ms < 0 Then
  WS_ms = WSprev
  WindDir = WindDirprev
  MaxWS_ms = MaxWSprev
  Invalid_Wind = 1
Else
  Invalid_Wind = 0
EndIf
WSprev = WS_ms
WindDirprev = WindDir
MaxWSprev = MaxWS_ms
'Correct barometric pressure in kPa to sea level
BP_hPa=BP_hPa+SeaLevelAdj
'Convert fractional relative humidity into percent relative humidity
RH=RH*100
'Calculate total solar flux in MJ/m^2 from flux density in W/m^2
'The multiplier to calculate total flux assumes
'the program execution rate (scan rate) is 60 s.
'If you change the program execution rate,
'you will need to recalculate this multiplier.
SlrTF_MJ=SlrFD_kw*6E-05
'Convert solar flux density in W/m^2 to kW/m^2
SlrFD_kw=SlrFD_kw*0.001
'Convert vapor pressure in kPa to hPa
VP_hPa=VP_hPa*10
'Convert barometric pressure in kPa to hPa
BP_hPa=BP_hPa*10
'Call Data Tables and Store Data
CallTable Hourly
CallTable Daily
NextScan
EndProg

```

Appendix C. Determining True North and Sensor Orientation

Orientation of the wind direction sensor is done after programming the data logger, and determining the location of True North. True North is usually found by reading a magnetic compass and applying the correction for magnetic declination; where magnetic declination is the number of degrees between True North and Magnetic North. The preferred method to obtain the magnetic declination for a specific site is to use a computer service offered by NOAA at www.ngdc.noaa.gov/geomag. The magnetic declination can also be obtained from a map or local airport. A general map showing magnetic declination for the contiguous United States is shown in FIGURE C-1.

Declination angles east of True North are considered negative, and are subtracted from 360 degrees to get True North as shown FIGURE C-2 (0° and 360° are the same point on a compass). For example, the declination for Logan, Utah is 11.78° East (11 August 2015). True North is $360^\circ - 11.78^\circ$, or 348.22° as read on a compass. Declination angles west of True North are considered positive, and are added to 0 degrees to get True North as shown in FIGURE C-3.

Orientation:

1. Establish a reference point on the horizon for True North.
2. Sighting down one pair of the ClimaVUE 50 north south posts, aim the pair at True North. If the wind is blowing and a flag or banner can be used to determine the true wind direction, the data logger displayed wind direction reading can be compared to the true wind direction.

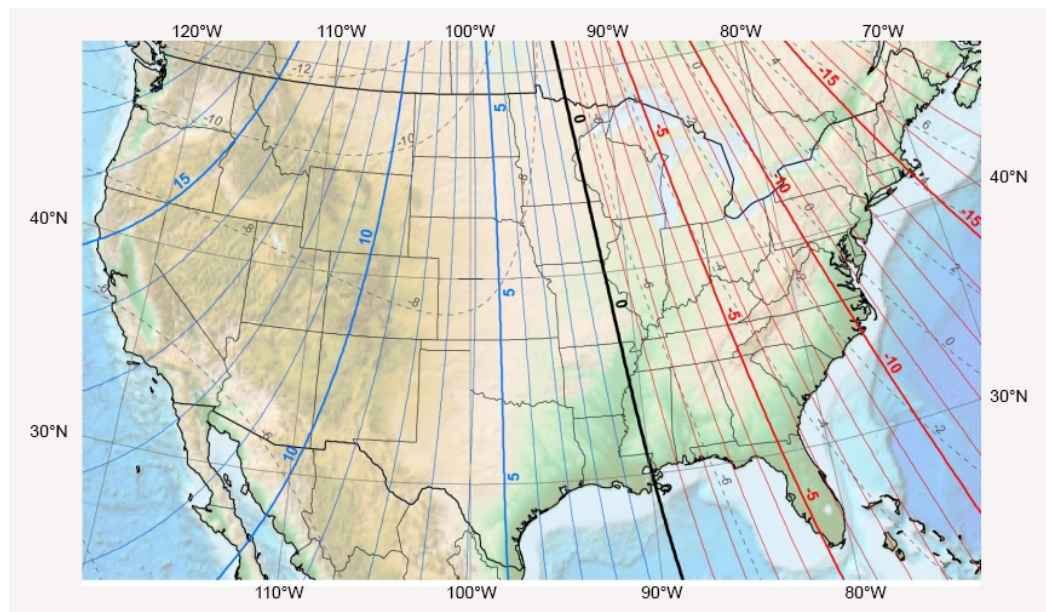

FIGURE C-1. Magnetic declination for the contiguous United States (2015)

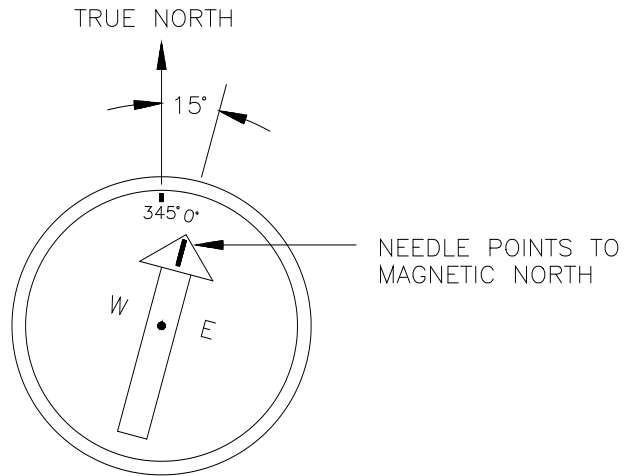

FIGURE C-2. Declination angles east of True North are subtracted from 360 to get True North

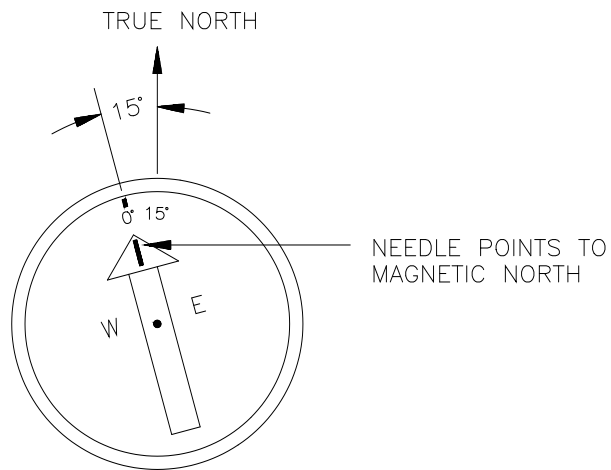

FIGURE C-3. Declination angles west of True North are added to 0 to get True North

Appendix D. SDI-12 Sensor Support

D.1 Introduction

SDI-12, Serial Data Interface at 1200 baud, is a protocol developed to simplify sensor and data logger compatibility. Only three wires are necessary — serial data, ground, and 12 V. With unique addresses, multiple SDI-12 sensors can connect to a single SDI-12 terminal on a Campbell Scientific data logger.

This appendix discusses the structure of SDI-12 commands and the process of querying SDI-12 sensors. For more detailed information, refer to version 1.3 of the SDI-12 protocol, available at www.sdi-12.org.

For additional information, refer to the [SDI-12 Sensors | Transparent Mode](#) and [SDI-12 Sensors | Watch or Sniffer Mode](#) videos.

D.2 SDI-12 Command Basics

SDI-12 commands have three components:

Sensor address (a) – a single character and the first character of the command. Use the default address of zero (0) unless multiple sensors are connected to the same port.

Command body – an upper-case letter (the “command”), optionally followed by one or more alphanumeric qualifiers.

Command termination (!) – an exclamation mark.

An active sensor responds to each command. Responses have several standard forms and always terminate with <CR><LF> (carriage return and line feed). Standard SDI-12 commands are listed in TABLE D-1.

Name	Command	Response ¹
Acknowledge Active	a!	a<CR><LF>
Send Identification	aI!	allccccccmmmmmmvvvxxx...xx <CR><LF>
Address Query	?!	a<CR><LF>
Change Address	aAb!	b<CR><LF>
Start Measurement	aM! aM1!...aM3!	atttn<CR><LF>
Start Concurrent Measurement	aC!	atttnn<CR><LF>
Send Data	aD0!...aD7!	a<values><CR><LF> or a<values><CRC><CR><LF>

TABLE D-1. ClimaVUE 50 SDI-12 Command and Response Set		
Name	Command	Response ¹
Continuous Measurement	aR7!	a<values><CR><LF>
Extended Commands	aXNNN!	a<values><CR><LF>
¹ Information on each of these commands is given in following sections.		

D.2.1 Acknowledge Active Command (a!)

The Acknowledge Active command (**a!**) is used to test a sensor on the SDI-12 bus. An active sensor responds with its address.

D.2.2 Send Identification Command (aI!)

Sensor identifiers are requested by issuing command **aI!**. The reply is defined by the sensor manufacturer. The following shows the reply for the ClimaVUE 50.

aI!	allccccccmmmmmvvxxx...xx<CR><LF>
a	Sensor SDI-12 address
ll	13 (SDI-12 version number 1.3)
ccccccc	CAMPBELL (8-character vendor identification)
mmmmmm	CLIM50 (6 characters specifying the sensor model)
vvv	3 characters specifying the sensor version (operating system)
xxx...xx	13 characters used for a serial number
<CR><LF>	Terminates the response

For example, if a ClimaVUE 50 has an SDI-12 address of 0, an OS of 5.00, and a serial number of VUE-500001036, the **I!** command will return:

```
013CAMPBELLCLIM50500VUE-500001036
```

D.2.3 Address Query Command (?!)

Command **?!** requests the address of the connected sensor. The sensor replies to the query with the address, *a*. This command should only be used with one sensor on the SDI-12 bus at a time.

D.2.4 Change Address Command (aAb!)

Multiple SDI-12 sensors can connect to a single SDI-12 terminal on a data logger. Each device on a single terminal must have a unique address.

A sensor address is changed with command **aAb!**, where *a* is the current address and *b* is the new address. For example, to change an address from 0 to 2, the command is **0A2!**. The sensor responds with the new address *b*, which in this case is 2.

NOTE

Only one sensor should be connected to a particular terminal at a time when changing addresses.

D.2.5 Start Measurement Commands (aM!)

A measurement is initiated with the **M!** command. The response to each command has the form *attn*<CR><LF>, where

a = sensor address

ttt = time, in seconds, until measurement data is available. When the data is ready, the sensor notifies the data logger, and the data logger begins issuing **D** commands.

n = the number of values returned when one or more subsequent **D** commands are issued. For the **aM!** command, *n* is an integer from 0 to 9.

When the **aM!** is issued, the data logger pauses its operation and waits until either it receives the data from the sensor or the time, *ttt*, expires. Depending on the scan interval of the data logger program and the response time of the sensor, this may cause skipped scans to occur. In this case make sure your scan interval is longer than the longest measurement time (*ttt*).

TABLE D-2. Example aM! Sequence

OM!	The data logger makes a request to sensor 0 to start a measurement.
00352<CR><LF>	Sensor 0 immediately indicates that it will return two values within the next 35 seconds.
0<CR><LF>	Within 35 seconds, sensor 0 indicates that it has completed the measurement by sending a service request to the data logger.
OD0!	The data logger immediately issues the first D command to collect data from the sensor.
0+.859+3.54<CR><LF>	The sensor immediately responds with the sensor address and the two values.

D.2.6 Start Concurrent Measurement Commands (aC!)

A concurrent measurement (**aC!**) command follows the same pattern as the **aM!** command with the exception that it does not require the data logger to pause its operation, and other SDI-12 sensors may take measurements at the same time. The sensor will not issue a service request to notify the data logger that the measurement is complete. The data logger will issue the **aD0!** command during the next scan after the measurement time reported by the sensor has expired. To use this command, the scan interval should be more than 10 seconds. The response to each command has the form *attn*<CR><LF>, where

a = the sensor address

ttt = time, in seconds, until the measurement data is available

nn = the number of values to be returned when one or more subsequent **D** commands are issued.

See the following example. A data logger has three sensors wired into terminal C1. The sensors are addresses X, Y, and Z. The data logger will issue the following commands and receive the following responses:

TABLE D-3. Example aC! Sequence	
XC!	The data logger makes a request to sensor X to start a concurrent measurement.
X03005<CR><LF>	Sensor X immediately indicates that it will have 5 (05) values ready for collection within the next 30 (030) seconds.
YC!	The data logger makes a request to sensor Y to start a concurrent measurement.
Y04006<CR><LF>	Sensor Y immediately indicates that it will have 6 (06) values ready for collection within the next 40 (040) seconds.
ZC!	The data logger makes a request to sensor Z to start a concurrent measurement.
Z02010<CR><LF>	Sensor Z immediately indicates that it will have 10 values ready for collection within the next 20 (020) seconds.
ZDO!	After 20 seconds have passed, the data logger starts the process of collecting the data by issuing the first D command to sensor Z.
Z+1+2+3+4+5+6+7+8+9+10<CR><LF>	Sensor Z immediately responds with the sensor address and the 10 values.
XDO!	10 seconds later, after a total of 30 seconds have passed, the data logger starts the process of data from sensor X by issuing the first D command.
X+1+2+3+4+5<CR><LF>	The sensor immediately responds with the sensor address and the 5 values.
YDO!	Ten seconds later, after a total of 40 seconds have passed, the data logger starts the process of data from sensor Y by issuing the first D command.
Y+1+2+3+4+5+6<CR><LF>	The sensor immediately responds with the sensor address and the 6 values.

D.2.7 Stopping a Measurement Command

A measurement command (**M!**) is stopped if it detects a break signal. A break signal is sent by the data logger before most commands.

D.2.8 Send Data Command (**aD0! ... aD7!**)

The Send Data command requests data from the sensor. It is issued automatically with every type of measurement command. The data logger issues the **aD0!** command once a service request has been received from the sensor. In transparent mode (Appendix D.3, *SDI-12 Transparent Mode (p. D-6)*), the user asserts this command to obtain data.

Depending on the type of data returned and the number of values a sensor returns, the data logger may need to issue **aD0!** up to **aD9!** to retrieve all data. A sensor may return up to 35 characters of data in response to a **D** command that follows an **M!** command.

Command: **aD0! (aD1! ... aD9!)**

Response: *a*<values><CR><LF> or
a<values><CRC><CR><LF>

where:

a = the sensor address

<values> = values returned with a polarity sign (+ or -)

<CR><LF> = terminates the response

D.2.9 Continuous Measurement Command (**aR7!**)

Sensors that are able to continuously monitor the phenomena to be measured can be read directly with the **R** commands. The response to the **R** commands mirrors the Send Data command (**aD0!**). A maximum of 75 characters can be returned in the <values> part of the response to the **R** command.

D.2.10 Extended Commands

Many sensors support extended SDI-12 commands. An extended command is specific to a make of sensor and tells the sensor to perform a specific task. They have the following structure. Responses vary from unit to unit. See the sensor manual for specifics.

Command: **aXNNNN!**

The command will start with the sensor address (**a**), followed by an **X**, then a set of optional letters, and terminate with an exclamation point.

Response: *a*<optional values><CR><LF>

The response will start with the sensor address and end with a carriage return/line feed.

The only extended command a customer might need is the following command which is used to enter a new pyranometer calibration factor when the rain gage funnel and pyranometer are replaced.

Operating system (OS) upgrades require additional equipment and extended commands and therefore are not practical for most customers. Contact a Campbell Scientific repair department for assistance if a OS upgrade is needed.

SDI-12 command (<i>a</i> is the sensor address)	Function
<i>aXc!</i>	Displays the pyranometer calibration
<i>aXcnnnn!</i>	Changes the pyranometer calibration number to <i>nnnn</i> Where: <i>nnnn</i> = calibration number

D.3 SDI-12 Transparent Mode

System operators can manually interrogate and enter settings in probes by using transparent mode. Transparent mode is useful in troubleshooting SDI-12 systems because it allows direct communication with probes. Data logger security may need to be unlocked before activating the transparent mode.

Transparent mode is entered while the computer is communicating with the data logger through a terminal emulator program. It is accessed through Campbell Scientific data logger support software or other terminal emulator programs. Data logger keyboards and displays cannot be used.

The terminal emulator is accessed by navigating to the **Datalogger** list in *PC200W*, the **Tools** list in *PC400*, or the **Datalogger** list in the *Connect* screen of *LoggerNet*.

 Watch the video: [SDI-12 Sensors | Transparent Mode](#).

The following examples show how to enter transparent mode and change the SDI-12 address of an SDI-12 sensor. The steps shown in Appendix [D.3.1, Changing an SDI-12 Address \(p. D-6\)](#), are used with most Campbell Scientific data loggers.

D.3.1 Changing an SDI-12 Address

The following example was done with a CR1000X, but the steps are only slightly different for CR1000, CR300-series, CR6-series, CR800-series, and CR3000 data loggers.

1. Connect an SDI-12 sensor to the CR1000X.
2. In *LoggerNet Connect*, under **Datalogger**, click **Terminal Emulator**. The terminal emulator window opens.
3. Under **Select Device**, located in the lower left side of the window, select the **CR1000X** station.
4. Click **Open Terminal**.

5. Select **All Caps Mode**.
6. Press Enter until the data logger responds with the *CR1000X>* prompt.
7. Type **SDI12** and press Enter.
8. At the *Select SDI12 Port* prompt, type the number corresponding to the control port where the sensor is connected and press Enter. The response *Entering SDI12 Terminal* indicates that the sensor is ready to accept SDI-12 commands.
9. To query the sensor for its current SDI-12 address, type **?!** and press Enter. The sensor responds with its SDI-12 address. If no characters are typed within 60 seconds, the mode is exited. In that case, simply type **SDI12** again, press Enter, and type the correct control port number when prompted.
10. To change the SDI-12 address, type **aAb!**, where *a* is the current address from the above step and *b* is the new address. Press Enter. The sensor changes its address and responds with the new address.
11. To exit SDI-12 transparent mode, click **Close Terminal**.

D.4 References

SDI-12 Support Group. *SDI-12: A Serial-Digital Interface Standard for Microprocessor-Based Sensors – Version 1.4*. River Heights, UT: SDI-12 Support Group, 2017. http://www.sdi-12.org/current_specification/SDI-12_version-1_4-Dec-1-2017.pdf.



Global Sales & Support Network

A worldwide network to help meet your needs



● Campbell Scientific
Regional Offices

● Sales Representatives

Australia

Location: Garbutt, QLD Australia
Phone: 61.7.4401.7700
Email: info@campbellsci.com.au
Website: www.campbellsci.com.au

Brazil

Location: São Paulo, SP Brazil
Phone: 11.3732.3399
Email: vendas@campbellsci.com.br
Website: www.campbellsci.com.br

Canada

Location: Edmonton, AB Canada
Phone: 780.454.2505
Email: dataloggers@campbellsci.ca
Website: www.campbellsci.ca

China

Location: Beijing, P. R. China
Phone: 86.10.6561.0080
Email: info@campbellsci.com.cn
Website: www.campbellsci.com

Costa Rica

Location: San Pedro, Costa Rica
Phone: 506.2280.1564
Email: info@campbellsci.cc
Website: www.campbellsci.cc

France

Location: Vincennes, France
Phone: 0033.0.1.56.45.15.20
Email: info@campbellsci.fr
Website: www.campbellsci.fr

Germany

Location: Bremen, Germany
Phone: 49.0.421.460974.0
Email: info@campbellsci.de
Website: www.campbellsci.de

South Africa

Location: Stellenbosch, South Africa
Phone: 27.21.8809960
Email: sales@campbellsci.co.za
Website: www.campbellsci.co.za

Southeast Asia

Location: Bangkok, Thailand
Phone: 66.2.719.3399
Email: thitipongc@campbellsci.asia
Website: www.campbellsci.asia

Spain

Location: Barcelona, Spain
Phone: 34.93.2323938
Email: info@campbellsci.es
Website: www.campbellsci.es

UK

Location: Shephed, Loughborough, UK
Phone: 44.0.1509.601141
Email: sales@campbellsci.co.uk
Website: www.campbellsci.co.uk

USA

Location: Logan, UT USA
Phone: 435.227.9120
Email: info@campbellsci.com
Website: www.campbellsci.com