

waterra.com

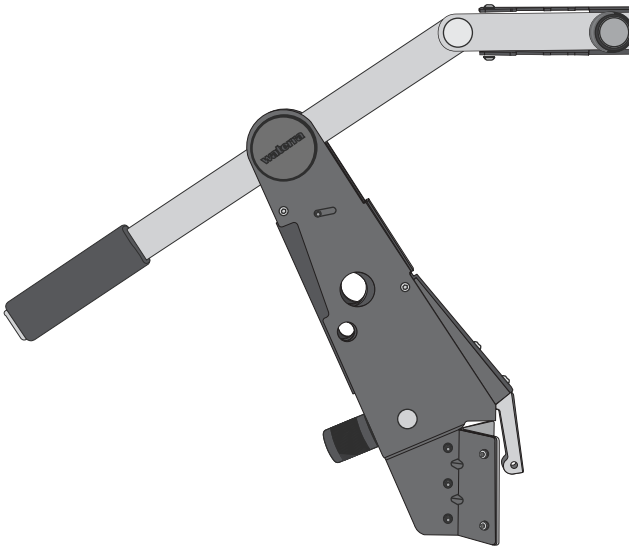

WLP-100 Lever Pump
Tubing Actuator
Owner's Manual

waterra Groundwater Monitoring Equipment & Supplies

SN#

2021

FEATURES

WLP-100 LEVER PUMP

The Waterra Lever Pump was designed to provide operators with a convenient, portable mechanism which would provide some mechanical advantage when manually operating the Waterra Inertial Pump, as well as facilitating the collection of samples with this system.

- *fully adjustable*
- *hinged tubing clamp*
- *suitable for use with Standard Flow, High Flow & Low Flow Inertial Pumps*
- *adapts to almost any size casing or protective well casing*
- *one handed operation*
- *reduces fatigue when purging large volumes from wells*

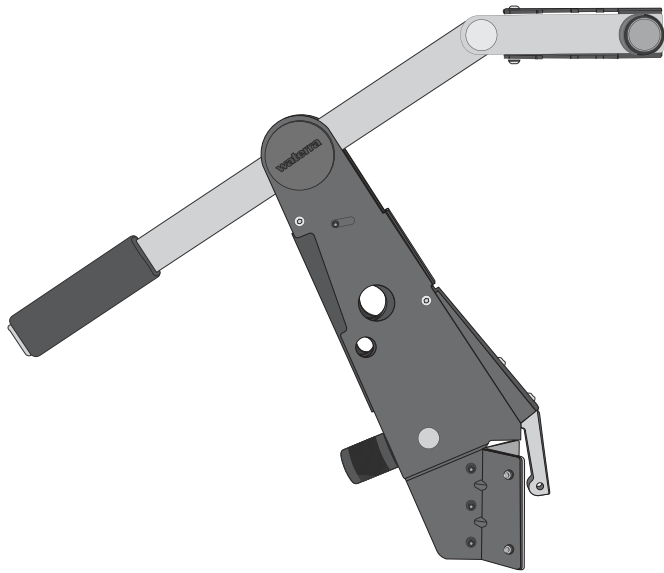

FEATURES

This actuator will fasten onto most above ground well completions quickly and easily. The tubing clamp is designed to accept Standard Flow, High Flow and Low Flow tubing and the handle is adjustable in order to accommodate various casing diameters and desired stroke lengths. The Lever Pump weighs approximately 8 lbs (3.6 kg).

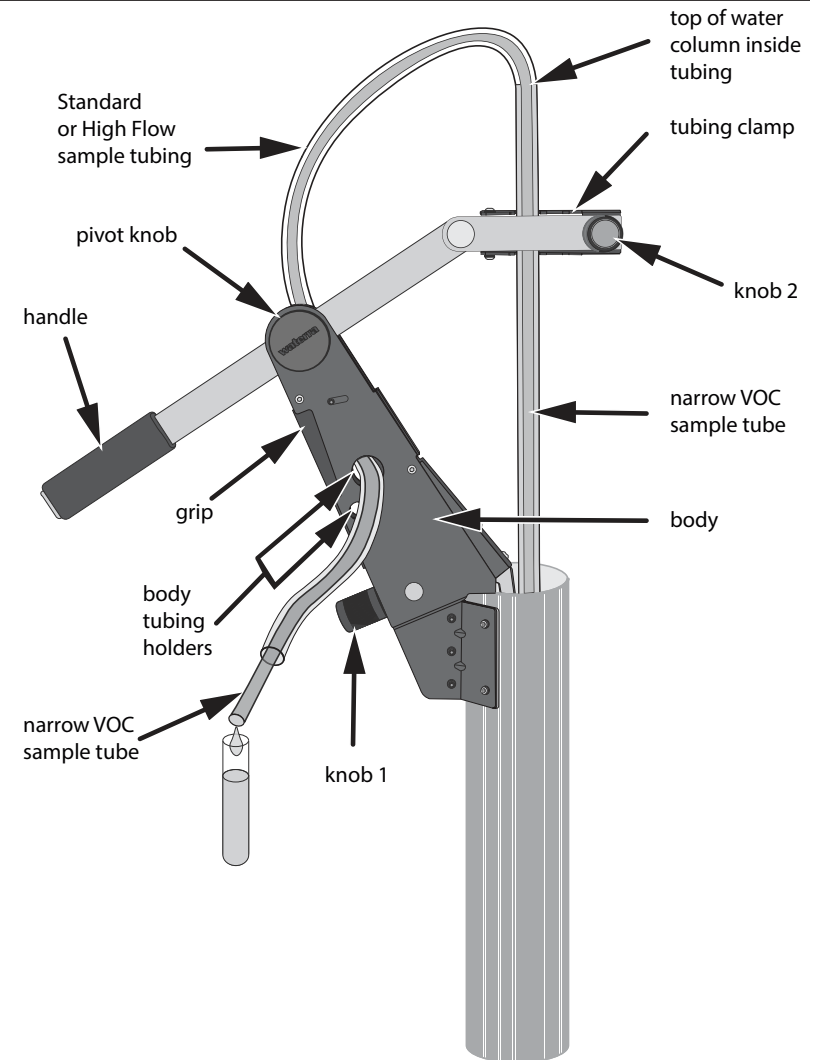

ASSEMBLY & OPERATION

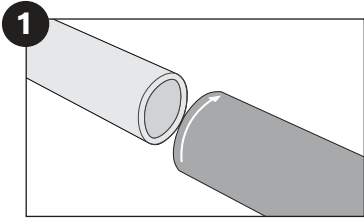

1) Attach the foot valve to the plastic tubing by threading the foot valve clockwise (right hand thread) on the tubing as far as possible. The threads on the foot valve will self-tap into the tubing to provide a strong, watertight connection. Test the connection by pulling vigorously on the foot valve.

2) Lower the foot valve and tubing to the desired depth (usually just above the bottom of the well) and cut the tube with approximately 4 feet extending above the well casing. Do not cut the tubing flush with the top of the casing in case there is an accumulation of silt at the bottom of the well. If this is the case, the Inertial Pump will remove this material and effectively make the total depth of the well greater. For dedicated installations, the tubing can be cut flush to permit capping of the well when not in use.

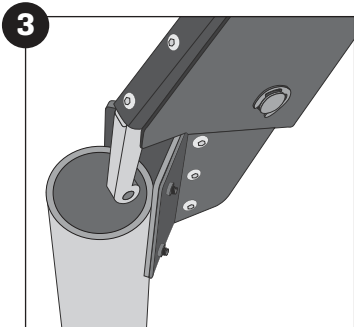

3) Fasten the WLP-100 Lever Pump on the top edge of the well casing or surface protective casing.

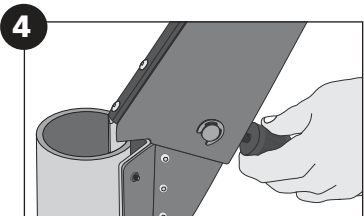

4) Tighten Knob 1 located at the base of the body.

ASSEMBLY & OPERATION

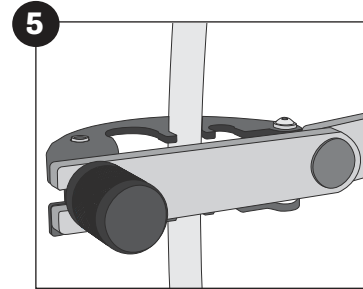

5) Fit the tubing in the appropriate cutout in the Tubing Clamp, with 4 to 5 feet of tubing protruding above the clamp. Close and tighten the tubing clamp with Knob 2, located at the tubing clamp.

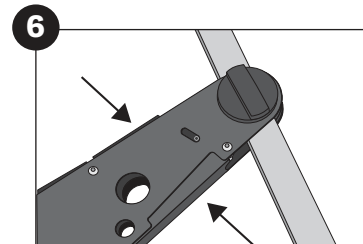

6) Squeeze the Grip to line up the holes in the Grip with the holes in the Body. Bend the extra 4 to 5 feet of tubing above the tubing clamp around and fit it through the Body Tubing Holder. Release the Grip. The discharge end of the tubing will then be held in place.

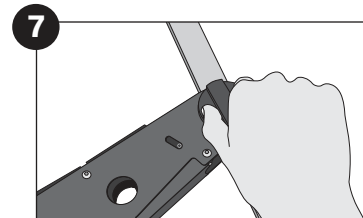

7) Align the tubing in the casing by using the Pivot Knob to adjust the position of the Handle. This avoids excessive rubbing and positions it for an effective stroke.

8) Pump water from the well by operating the Handle at a rate of between 90 to 120 strokes per minute. To maximize the pumping rate, rapid and abrupt up stroke (pushing down on the handle) should be used to impart greater upward momentum to the column of water.

PLEASE NOTE:

The pump will lift water laden with silt and sand. However, after pumping is completed, the sediment in the column of water within the tube may settle out and clog the foot valve. To prevent this, we recommend clearing the tube after use. This may be done by inverting the tube in the well.

To invert the tubing, pull up about 8 feet of tubing, looping it over and insert the open end back into the well. Push down the open end while simultaneously pulling up the other end.

WARRANTY

Waterra Pumps Limited warrants that each new Lever Pump will be free from any defects in material or workmanship for the relevant warranty period, under normal use and maintenance. Necessary repairs shall be made and replacement parts provided at no cost to the consumer when Waterra acknowledges that such defects are attributable to faulty material or workmanship at the time of manufacture. This warranty is not transferable.

Warranty period: All components 6 months.

EXCLUSIONS AND CONDITIONS

The Waterra Warranty **does not cover** any repairs required as a result of collision, accident, striking an object, abuse, misuse, lack of required maintenance or use of an incorrect power source.

The Waterra Warranty **does not cover** any repairs required as a result of any attachments, parts or devices installed or repairs done by a party other than Waterra Pumps Limited.

The Waterra Warranty **does not cover** any Lever Pump that has been modified, altered, disassembled or remodeled.

The Waterra Warranty **does not cover** normal maintenance service such as tightening screws, bolts or fittings; and lubrication and/or replacement of parts that are susceptible to natural wear.

WARRANTY

OWNER'S OBLIGATION

The owner agrees to follow all safety procedures outlined with this equipment and follow the maintenance schedule as indicated in this Owner's Manual. A record must be kept of regular inspections and maintenance performed.

DISCLAIMER

To the extent that the law permits, Waterra Pumps Limited disclaims any responsibility for the loss of time or use of the Lever Pump, transportation or towing costs or any other indirect, incidental or consequential damage, inconvenience, commercial loss or personal injury. The warranty is not valid if the product is not paid for in full within 60 days of the invoice date.

RETURNING THE LEVER PUMP TO WATERRA

Waterra requires that all customers notify Waterra prior to returning their Lever Pump under the Waterra warranty program. The Lever Pump will only be accepted if it has been thoroughly cleaned and decontaminated. The Lever Pump must be properly packaged and all fuel must be removed from the pump prior to shipping. Please contact Waterra in order to obtain a shipping address.

CONTACTING WATERRA

Visit www.waterra.com to download this manual or to obtain our current phone numbers and return addresses.

Canada & International

Waterra Pumps Limited
5200 Dixie Road, Unit 17
Mississauga, ON L4W 1E4
CANADA
tel: 905.238.5242
fax: 905.238.5704
email: sales@waterra.com

United States

Waterra U.S.A. Inc.
36 Ranch Creek Road
Peshastin, Washington
USA 98847
Tel: 360.738.3366
Fax: 360.738.3399
email: waterra@openaccess.org