

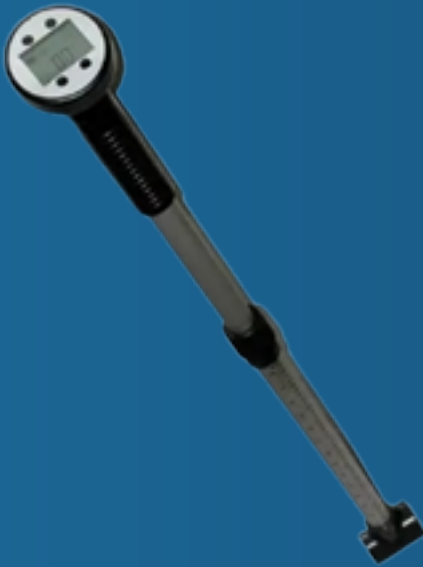

SURFACE WATER  
APPLICATIONS



# HydroTerra

Environmental Monitoring Specialists

## SURFACE WATER FLOW AND DISCHARGE MONITORING

Solutions from HydroTerra

[hydroterra.com.au](http://hydroterra.com.au)



## HydroTerra Surface Water Flow and Discharge Solutions

**1. Handheld Flow Probe**

**2. Handheld Sontek FlowTracker2**

**3. Tipping Bucket Flow Gauge**

**4. Use of Leveloggers**

**5. HydroMace XCi from Mace**

**6. Unidata Neon and Starflow QSD combination**

**7. Geolux**

- LX-80 Radar Level Sensor
- RSS-2-300W Surface Velocity Radar
- RSS-2-300WL Radar Flow Meter
- HydroStation

Flow Technology	Example Applications	Advantages	Disadvantages
<b>1. Handheld flow probe</b>	Open channel flow where single point cost effective data are required.	<ul style="list-style-type: none"> <li>- Simple.</li> <li>- Portable.</li> <li>- Non-intrusive.</li> <li>- Cost effective.</li> </ul>	<ul style="list-style-type: none"> <li>- Subject to reproducibility errors.</li> <li>- Not set up for continuous data collection.</li> <li>- Generally lower accuracy.</li> </ul>
<b>2. Handheld FlowTracker</b>	Open channel flow e.g. stream gauging for validation of stage to flow ratings.	<ul style="list-style-type: none"> <li>- Portable.</li> <li>- High accuracy with internal QA/QC.</li> <li>- Can set up channel profile templates, allowing easier repeat gauging events.</li> <li>- Embedded GPS.</li> </ul>	<ul style="list-style-type: none"> <li>- Not set up for continuous data collection.</li> <li>- Generally higher cost instrument.</li> <li>- Measurements limited by wading depth accessibility.</li> </ul>
<b>3. Tipping Bucket Flow Gauge</b>	Very low flow / low level applications (e.g. lysimeters and channels or pipes measuring a 'trickle').	<ul style="list-style-type: none"> <li>- Can capture data for very low flow /low level scenarios.</li> <li>- Volume pulse output can be recorded either by standalone data logger or full telemetry system.</li> </ul>	<ul style="list-style-type: none"> <li>- Dependent on appropriate installation to ensure flow data are accurately captured.</li> <li>- Requires ongoing maintenance to prevent or address blockages.</li> <li>- Can easily overflow if tipping bucket rating exceeded.</li> </ul>
<b>4. Leveloggers</b>	Typically used with a constructed weir or flume within an open channel with known rating (stage to flow relationship).	<ul style="list-style-type: none"> <li>- Level sensors are relatively inexpensive and reliable.</li> <li>- Flexible installation, providing sensor level can be related to the cease to flow (CTF) height (can use a submersible transducer or non-contact radar).</li> <li>- Allows continuous calculation of discharge.</li> </ul>	<ul style="list-style-type: none"> <li>- Requires calibration to develop site specific rating.</li> <li>- Requires appropriate installation and survey work.</li> <li>- Validation can be labour intensive.</li> <li>- Significant sources of error, such as debris, standing water, erosion etc.</li> </ul>
<b>5. HydroMace</b>	Open natural channel. Constructed channel (e.g. pipe or box culvert).	<ul style="list-style-type: none"> <li>- Directly measures velocity, offering powerful option for continuous flow monitoring.</li> <li>- Includes fully integrated telemetry system.</li> </ul>	<ul style="list-style-type: none"> <li>- Doppler technologies are impacted by turbulent conditions.</li> <li>- Sensor can become buried or covered with debris, interfering with readings.</li> <li>- Minimum water depth of around 4-5 cm to get meaningful measurements.</li> <li>- Requires survey work for channel profile.</li> <li>- Must be installed in-stream or in-pipe.</li> </ul>
<b>6. Unidata Neon + Starflow QSD</b>	Open natural channel. Constructed channel (e.g. pipe or box culvert).	<p>As per Mace, however this combination can also:</p> <ul style="list-style-type: none"> <li>- Control external devices via switching output based on custom triggers (such as autosamplers or pumps).</li> <li>- Integrate with a wide variety of additional instruments such as water quality meters, weather stations, rain gauges etc.</li> </ul>	<ul style="list-style-type: none"> <li>- As per Mace above</li> </ul>
<b>7. Geolux Radar</b>	Open natural channel. Constructed channel (e.g. pipe or box culvert). Deeper channels.	<ul style="list-style-type: none"> <li>- Directly measures velocity, offering powerful option for continuous flow monitoring.</li> <li>- Can be mounted to existing structures in deeper waters where other instrument cannot be deployed (e.g. bridge).</li> <li>- Includes fully integrated telemetry system.</li> </ul>	<ul style="list-style-type: none"> <li>- Higher cost compared to simpler technologies</li> <li>- Requires survey work for channel profile.</li> <li>- Problematic data in very low flow / low level conditions.</li> </ul>

Another key technology group is inline pipe flow meters, however this is a large category and has been excluded from the above summary.

# 1. Handheld Flow Probe

Starting with a very straightforward method. A flow probe, such as the FP111, FP211 and FP311, is a device used to measure water velocity in open channels and partially filled pipes. It typically consists of a propeller sensor attached to a telescopic handle with a digital display. The probe measures the speed of water flow, which can be used to calculate flow rates in streams, rivers and other water bodies.



ALSO

FOR RENT



Flow probe propeller with magnetic sensor



Digital Display

## 2. Handheld SonTek FlowTracker2



The SonTek FlowTracker2 is a handheld device used to measure flow rate in streams and rivers. It utilises acoustic Doppler velocimetry (ADV) to measure water velocity and integrates this with depth and width measurements to calculate discharge (flow rate). The FlowTracker2 is designed for portability and ease of use in various environments like natural streams, canals and even stormwater systems.

The FlowTracker2 has an acoustic sensor that transmits sound waves into the water. As the water moves, it causes a change in the frequency of the reflected sound waves, a phenomenon known as the Doppler effect. The amount of frequency shift is directly proportional to the water velocity. The instrument analyses these frequency shifts to determine the velocity components in multiple directions (usually 2D or 3D) at a specific point in the water column. By measuring velocity at multiple points across a stream or river cross-section and combining it with depth measurements, the FlowTracker2 can calculate the total discharge (volume of water flowing per unit time).

*ALSO*  
**FOR RENT**



SonTek FlowTracker2

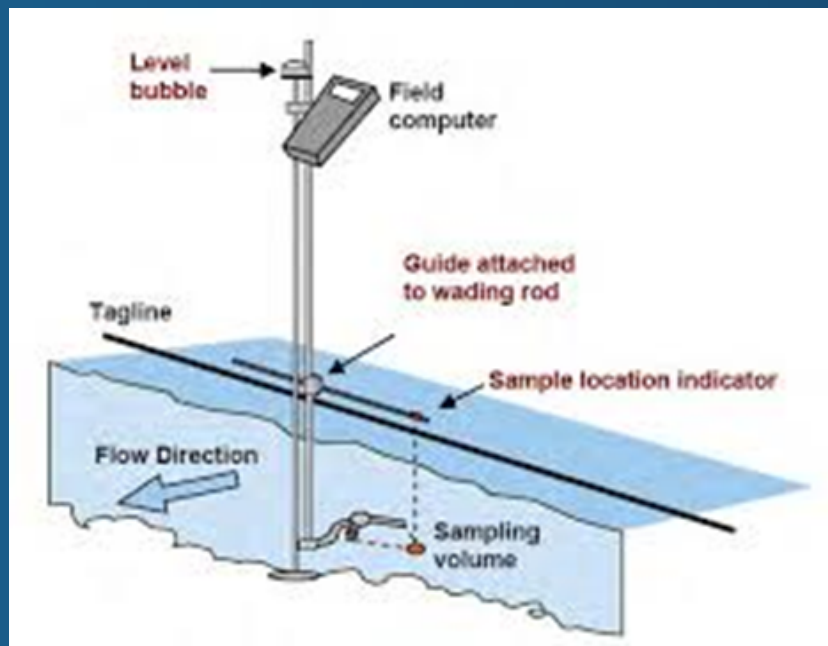

### 3. Tipping Bucket Flow Gauge

This is an option for applications where water flowing out of a pipe, drain or similar outlet needs to be monitored. Traditional flow measurement techniques are not suitable as the pipe may not be full or there is insufficient flow. The tipping bucket flow gauge uses a 0.5l or 1.0l bucket that tips when it fills to maximum and activates a read switch. The read switch is connected to a datalogger that counts the tips and works out flow rate over time.

Typical applications include:

- Monitoring at basin outlets of any kind of industrial water, grey water or storm water retention basins.
- Sewer network injections into a collection basin.
- Drain output – water discharge out of a treatment or intermittent storage basin.
- Pump testing.

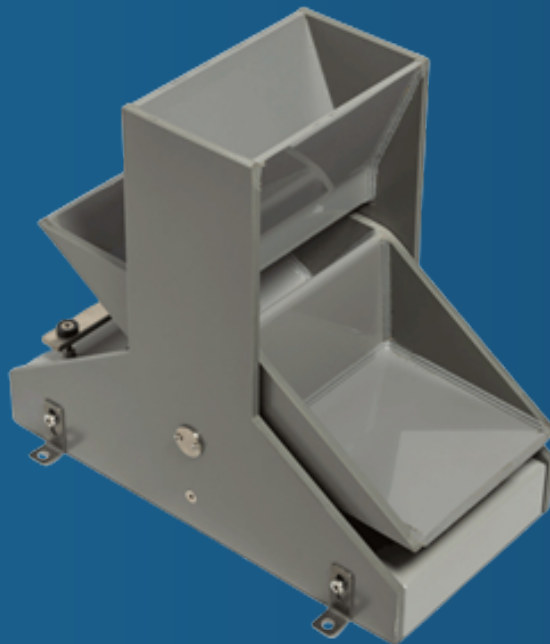

## 4. Use of Leveloggers



Leveloggers are used in association with weir and flume rating curves to determine discharge. What is a rating curve? Rating curves are used to determine the discharge of water in a channel by measuring the water level (head) and using the curve to find the corresponding discharge.

Further work has been done on this by the USGS in Arizona using Solinst Leveloggers. This is called the Continuous Slope Area (CSA) method.

The Continuous Slope-Area (CSA) method involves setting up a stretch (or reach) where continuous water level data is collected in a stream. Three or more water level dataloggers are installed in the stretch; each datalogger is located in a cross-section of the stream with similar characteristics including shape, slope and flow.

A great deal of research and field measurements (including LiDAR) goes into selecting appropriate stream reaches. Ideal locations include a straight stretch that is stable and not frequently scoured or filled. The reaches selected are also in areas that are usually inaccessible during flooding.

Surveys and field data are also used to determine the geometry and slope of the channel, which are required to calculate stream discharge along with the water level measurements.

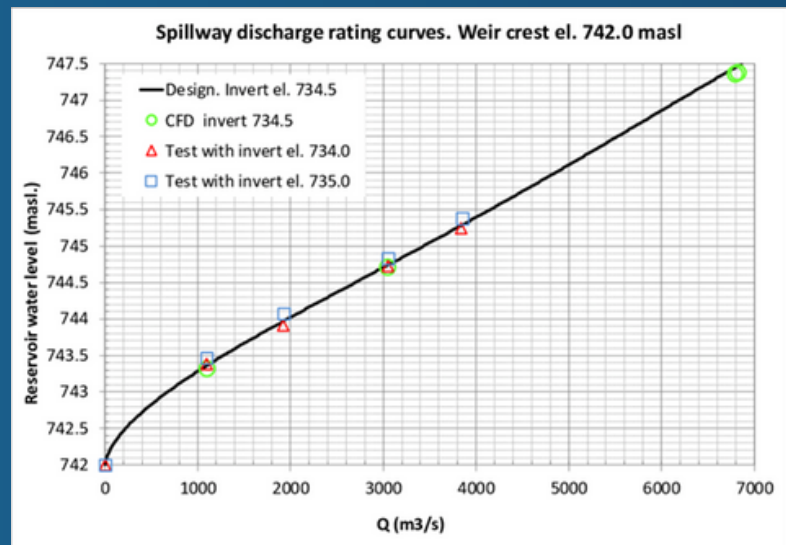

**Step 1: • Survey A**  
**• Measure stage (H) at PS1, PS2**

**Step 2: Estimate discharge**  

$$Q = \frac{1}{n} A R^{2/3} S^{1/2}$$
 (SI units)

## 5. HydroMace XCi from Mace

The HydroMace XCi can be setup as a complete system consisting of the datalogger and telemetry unit plus associated sensors. HydroMace XCi applications focus on flumes and weirs, partially filled open pipes or open channels as well as partially filled closed pipes.

*Flume and Weir applications*

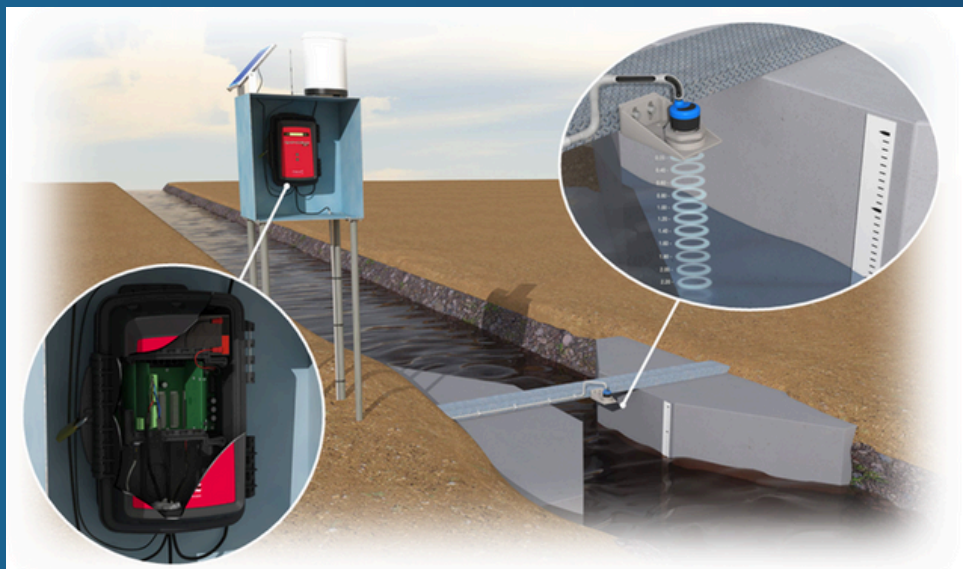

The HydroMace XCi includes built-in weir and flume equations and a look-up table that enables the user to interface downward looking ultrasonic or submerged depth sensors and convert the depth readings to flow rate readings. The HydroMace XCi includes equations for all major flume and weir types including:

- Parshall flumes
- V-notch weirs (30°, 45°, 60°, 90°)
- Cipoletti weir
- Replogle flume
- Rectangular weir (contracted/suppressed)
- 35-point user defined "Look-up" table

In the example above, a MACE EchoFlo ultrasonic depth sensor is used to determine depth. This provides a flow or discharge using the built-in equation for that particular flume or weir type.



MACE EchoFlo ultrasonic depth sensor

## 5. HydroMace XCi from Mace

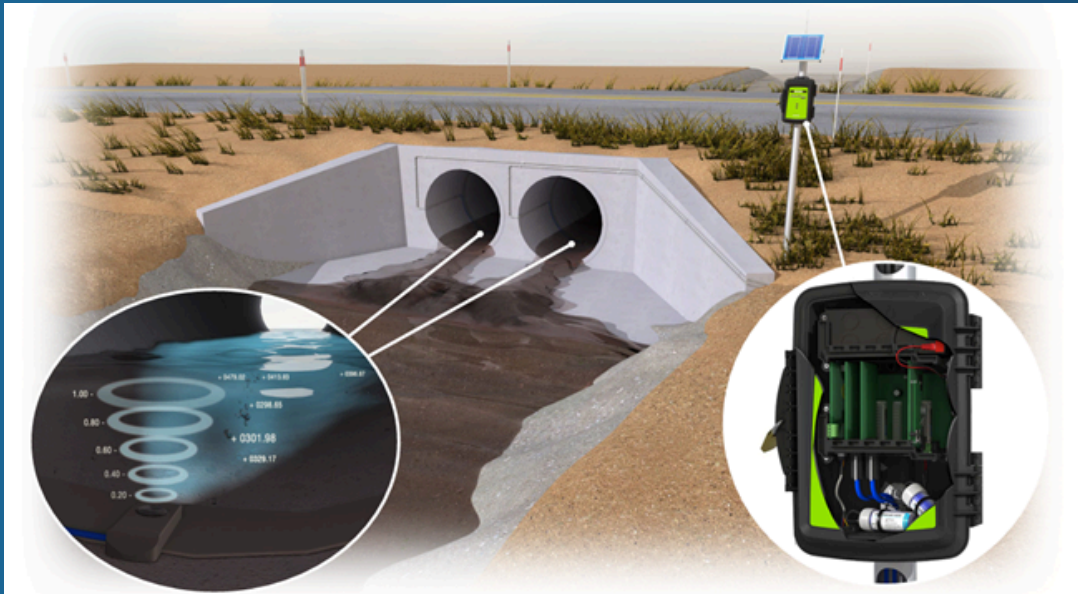

*The above application is within partially filled open pipes or open channels – for example stormwater.*

Typically, stormwater is conveyed through open channels and partially full pipes. The MACE FloPro XCi is best suited to measure these flows.

The often turbulent flows with high levels of suspended solids are perfect for MACE Doppler ultrasonic flow measurement. Combined with a downward looking ultrasonic depth sensor, storm flows up to 10 m/s (33 ft/s) can be accurately measured.

For this application either a MACE Doppler ultrasonic area or velocity sensor is used or a combination of a MACE Doppler ultrasonic velocity sensor and a MACE EchoFlo ultrasonic depth sensor.

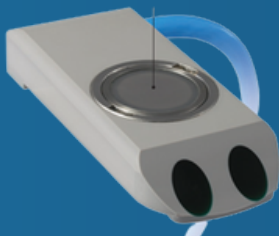

MACE Doppler ultrasonic area or velocity sensor

OR

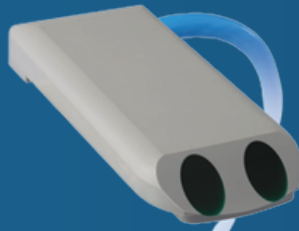

MACE Doppler ultrasonic area or velocity sensor



MACE EchoFlo ultrasonic depth sensor

## 5. HydroMace XCi from Mace



*The above application is for partially filled closed pipes.*

There are countless numbers of pipes across water districts and wastewater networks that do not run full all the time. Whilst from a measurement perspective it is preferable to measure flow in a full pipe, from a practical viewpoint it is often either difficult to achieve full flow under all conditions or just not economic to change.

A major problem with measuring flow in partially filled closed pipes is access to the inside of these pipes in which to measure the flow. Traditionally, these flows have gone un-monitored as no monitoring point/s are accessible or, alternatively, costly civil works have been required to make access points.

For this application, using a MACE FloPro XCi in conjunction with a MACE insertion velocity sensor and a MACE EchoFlo ultrasonic depth sensor, the monitoring of partially full pipes without the need for costly pipework alterations is a reality.



MACE insertion velocity sensor

AND



MACE EchoFlo ultrasonic depth sensor

## 6. Unidata Neon and Starflow QSD Combination



ALSO  
FOR RENT

A picture showing a typical installation with the Neon in a solar-powered enclosure with telemetry. The Starflow QSD is mounted on a concrete base in a channel.

HydroTerra has configured many high-end robust systems using a combination of the Unidata Neon dataloggers and Starflow QSD. These systems have proven their reliability over time and in challenging conditions.



Applications include weirs and flumes, open channels, partly filled pipes and natural streams. Many of these have complex velocity characteristics. Turbulence, waves, stream slope, bed and wall unevenness, rocks and debris, all combine to create an unpredictable velocity profile. To account for these effects, the Starflow QSD analyses up to one thousand separate velocity measurements and statistically determines the mean velocity. This approach provides a good "average velocity" even under difficult conditions.

*Note: the Starflow QSD is not a "current profiler", that is it does not record a detailed velocity profile. The Starlog companion software allows a user to define the stream, channel or pipe profile, so that the velocity and depth readings can be converted to a true flow or discharge reading.*

## 6. Unidata Neon and Starflow QSD Combination



### Starflow QSD - Ultrasonic Doppler Instruments only (15 m cable)

6527B	Starflow QSD Ultrasonic Velocity/Level Sensor - SDI-12/Modbus
6527B-BA	Starflow QSD Ultrasonic Velocity/Level and Barologger - SDI-12/Modbus
6527B-S	Starflow QSD Ultrasonic Velocity/Level Sensor - up to 50 m cable
6537A	Starflow QSD Ultrasonic Velocity/Level/Electrical Conductivity - SDI12/Modbus
6537A-BA	Starflow QSD Ultrasonic Velocity/Level/Electrical Conductivity and Barologger - SDI12/Modbus
6537A-S	Starflow QSD Ultrasonic Velocity/Level/Electrical Conductivity - up to 50 m cable
6515D	Starflow QSD Barometric Correction Dongle

There are a number of variants of the Starflow QSD as listed above. The barologger option would be mounted in the support enclosure and is used to compensate the StarFlow QSD Level Sensor for atmospheric variations in pressure.

A control option is also available with this setup. Open-channel irrigation water intakes can be monitored for water level or flow and they can be optionally controlled by opening and closing a gate to deliver programmed flow.

## 7. Geolux



Geolux specialises in non-contact, radar-based sensors used for environmental monitoring, providing contactless measurement of water levels, surface velocity and snow depth. Non-contact sensors, in general, offer benefits like minimal maintenance, simple installation and reliable measurements under harsh conditions by avoiding direct physical interaction with the target. Geolux's radar technology achieves this by transmitting electromagnetic waves and measuring the reflected signal's frequency shift to determine distance and other parameters.

By developing instruments that use non-contact radar technology to measure water level and water flow, Geolux focuses on managing floods and measuring flow. Installation of the instruments installed above the water, usually on the existing overhead structure such as a bridge, is easy, fast and requires minimal maintenance.

### **LX-80 Radar Level Sensor.**

Contactless radar level meter designed for precise distance measurement from the instrument to the surface of the various fluids. This functionality is achieved by transmitting an electromagnetic wave in 80 GHz frequency range (W band), and measuring the frequency shift of the electromagnetic wave reflected from the water surface.

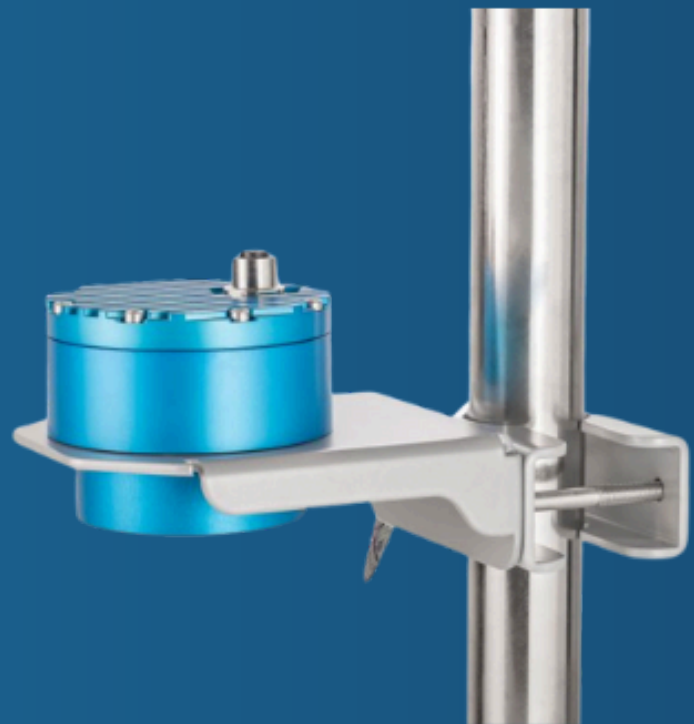

LX-80 Radar Level Sensor

### **RSS-2-300W Surface Velocity Radar**

The RSS-2-300W Surface Velocity Radar provides contactless surface flow velocity measurement. Contactless radar technology enables quick and simple sensor installation above the water surface with minimum maintenance. The radar operates in K-band (24.075 GHz to 24.175 GHz) and provides flow speed readings 10 times per second.



RSS-2-300W Surface Velocity Radar

### **RSS-2-300WL Radar Flow Meter**

The RSS-2-300WL Radar Flow Meter also provides contactless surface flow velocity measurement. In addition, the Geolux RSS-2-300WL has an integrated radar surface velocity and water level meter. Contactless radar technology enables quick and simple sensor installation above the water surface with minimum maintenance.

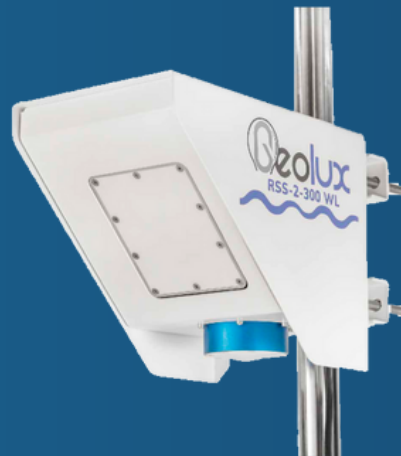

RSS-2-300WL Radar Flow Meter

Calculation of the total flow discharge is internally implemented within this instrument by combining surface velocity measurement, water level measurement and a configured cross-section of the river or channel. Defining the measurement parameters such as profile cross-section, material of the edges, location of the sensor above the water and all other instrument settings can be easily set with the Geolux configuration application using any available communication interface.

## 7. Geolux

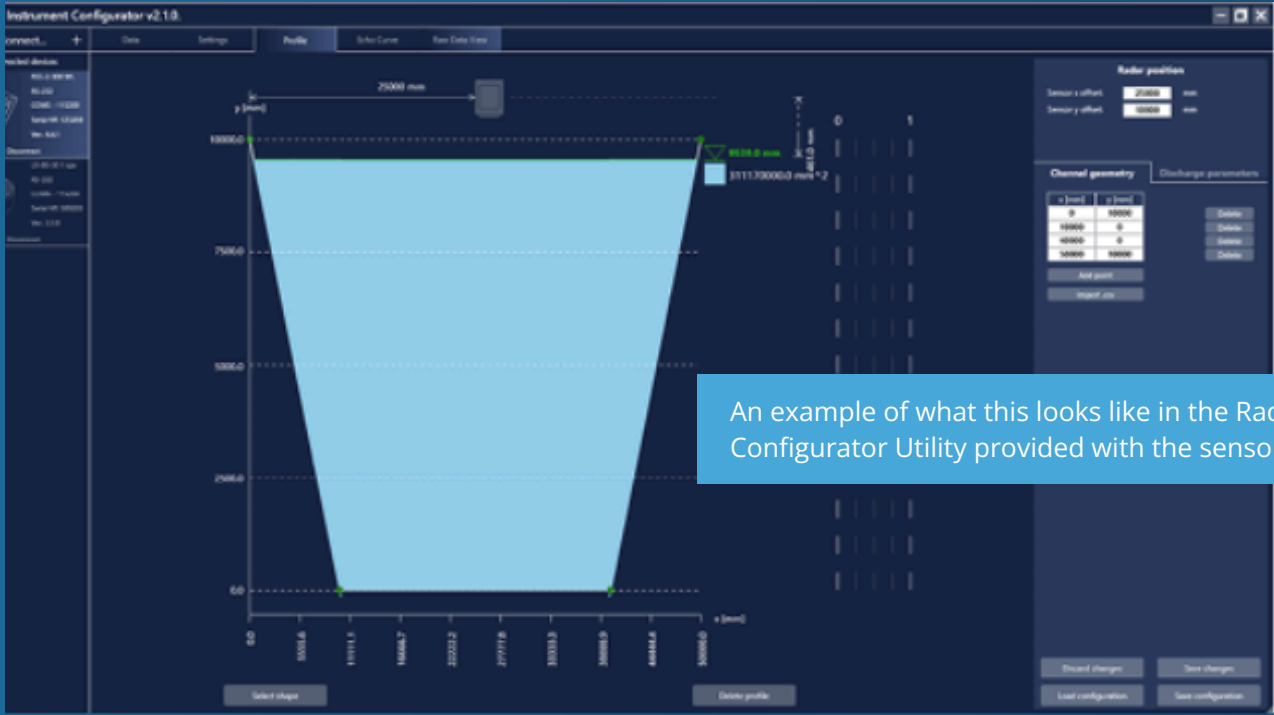

An example of what this looks like in the Radar Configurator Utility provided with the sensor.

***The channel geometry is defined in the sensor.***

In addition, the sensor supports the entry of k-factor values corresponding to different water level values. The k-factors represent an adjustment to the measured surface velocity at different levels in the water body. Using these will improve the accuracy of the calculated discharge flow. The k-factor values can also be estimated using the software. It is important to note that flow velocity is not uniform in a water body.

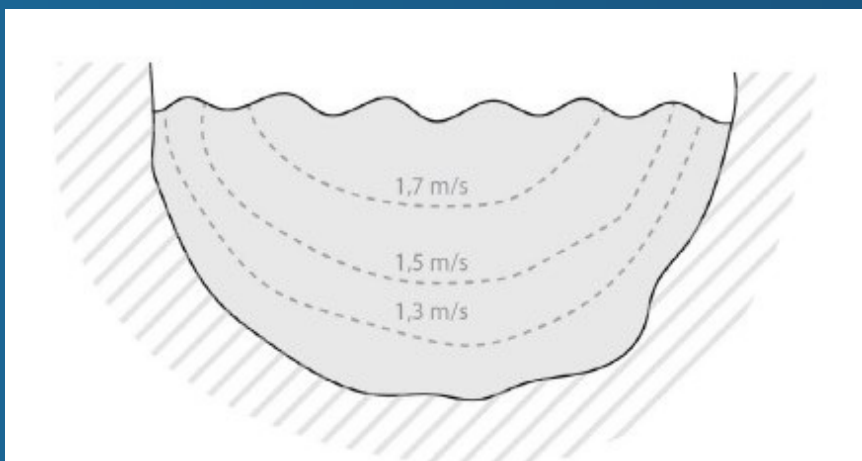



### **HydroStation**

The Geolux HydroStation is an automated hydrological monitoring station that integrates several Geolux products for tracking hydrology parameters. The HydroStation contains a solar panel, battery, SmartObserver datalogger with integrated communication module and Geolux radar instruments for measurement of water level and surface velocity. Integration of third-party sensors for meteorological measurements, water quantity or air quality and similar instruments is possible and easy to install.

The Geolux HydroView cloud-based software enables continuous real-time monitoring of all measurements and easily configures the settings of all stations and instruments within working parameters.

To support the HydroStation, Geolux offer various mounting solutions, including bridge mounts, extended bridge mounts and cantilever mounts.

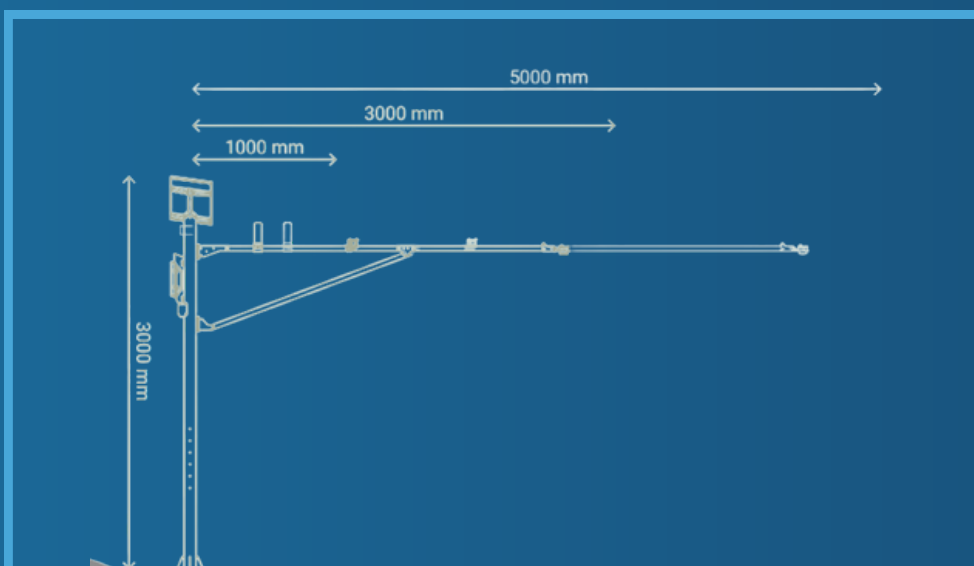
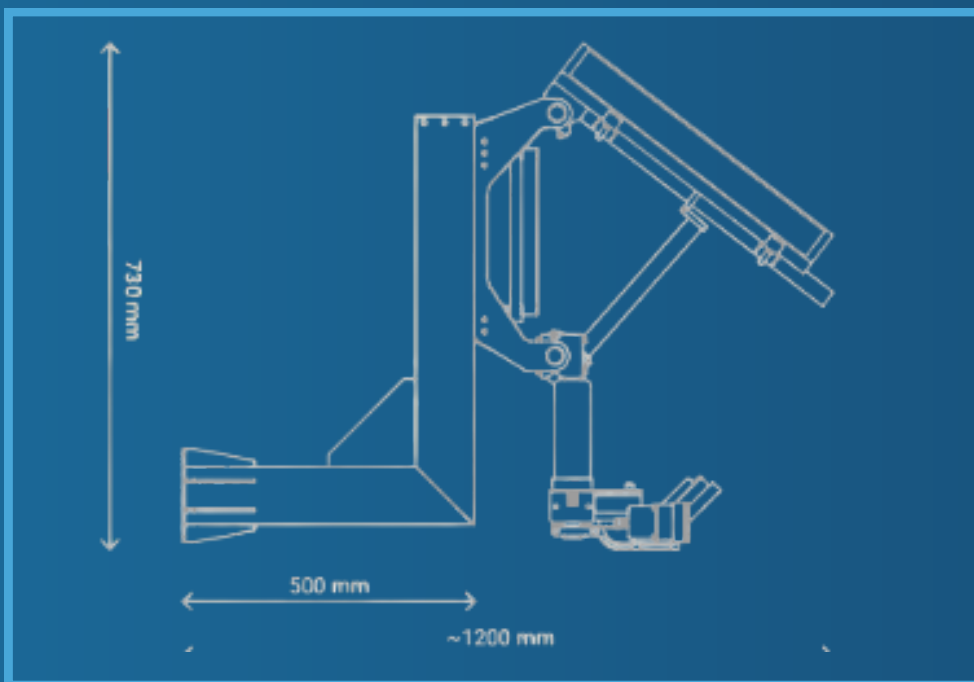
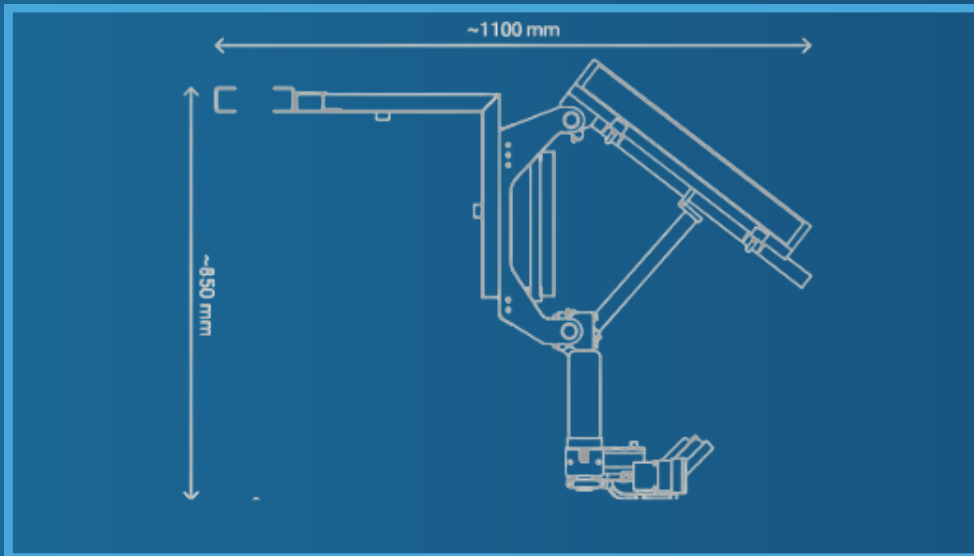

## Marketplace & Rental



### Product Sales

Most suitable equipment and consumables for customer applications

### Rental Services

Short-term monitoring equipment supply

## Workshop, Support & Training



### Workshop

Scheduled maintenance, calibration services and repairs in HydroTerra's Workshop.

### Webinars and Training

held regularly to facilitate education



## Field Services

### Site Collection



Undertaking field measurements and analysing collected samples in a lab



### Site Data Management

Generating publishable quality coded data files of known provenance



### Site Reporting

Reporting on the sites operational and environmental compliance



## Monitoring Systems



### System Design

Developing monitoring plan and monitoring system design



### System Specification

Specifying measurement points, equipment choices and data reporting



### System Supply

Sourcing best software, hardware, hosting and telco options



### Configure and Test

On selected systems design, calibration and alarm setup



### System Install

Building and installing monitoring and sampling systems onsite.



### System Oversight

Overseeing the monitoring system to ensure measurements are being captured and reported.



### System Maintenance

Implementing the maintenance programs scheduled and unscheduled needs.



### System Training

Deliver training programs to site operators enabling in-house maintenance and reporting.



Need the right solution for your  
Surface water flow or discharge  
monitoring application?

Contact HydroTerra  
Today!

[sales@hydroterra.com.au](mailto:sales@hydroterra.com.au)  
(03) 8683 0091  
[hydroterra.com.au](http://hydroterra.com.au)