

Pollusense User Manual



Multi-Parameter Portable Air Quality Monitor



Dust
Pollution



Emission
Gases



Odourful
Gases

ABOUT OIZOM

Oizom is a Smart Air Quality Monitoring solutions company offering data-driven environmental solutions for better decision-making. Using our sensor-based hardware, we monitor various environmental parameters related to air quality, odour, weather, and radiation. Our vision is to empower industries with data-driven Accurate and Affordable solutions for better decision-making while keeping the environment at our core.

ABOUT THIS DOCUMENT

Thank you for choosing Pollusense™ This document is a comprehensive user manual that will help with the identification, operation & maintenance of Pollusense™.

It is important to open the two latches with the latch key and place the nano-sim card inside the motherboard, before switching on the Pollusense for GSM Connectivity

REVISION HISTORY

Revision	Date	Created	Approved	Comments
1.0	07/11/2024	BN	SP	User Manual created
2.0	24/06/2025	BN	SP	Battery downgraded due to new IATA norms

Table of Contents

1. Definitions	4
2. Safety	4
3. Product Specifications	5
3.1 Product Features	6
3.2 Product Identification	7
3.3 Sensor Specifications	8
3.4 Technical Specifications	9
3.5 Power Supply Unit	10
4. Preparing Pollusense for use	11
4.1 Transportation	11
4.2 Prerequisites for Installation	12
4.2.1 Unboxing	12
4.2.2 Identification of Components	13
4.3 Initial Setup	13
4.3.1 Power Connection	14
4.3.2 LED Indications	15
4.3.3 Display	16
4.3.4 Connectivity	16
4.3.4.1 GSM	19
4.3.4.2 WiFi	20
4.3.5 Data Visualization	20
4.3.6 Sensor Configuration	21
4.3.7 Device Configuration in Envizom™	22
5. Instructions for Location Selection	23
6. Operation and Maintenance	25
6.1 Cleaning	25
6.1.1 Device	25
6.1.2 Sample inlet and outlets	26
6.2 Replacements	26
7. Diagnosis/Debugging	27
7.1 Reboot	27

1. Definitions

OGS	Oizom Gas Sensor is a proprietary sensor used for gas monitoring.
Calibration Hood	It is an accessory for the fitment of the gas inlet to be used during onsite calibration with compressed gas cylinders.
GSM	The Global System for Mobile Communications (GSM) is a standard to describe the protocols for second and third-generation (2G/3G) digital cellular networks used by mobile devices.
LTE	Long-Term Evolution (LTE), referred to as 4G LTE is a standard for wireless broadband communication for mobile devices and data terminals.
Wi-Fi	Wi-Fi is a family of wireless network protocols which are commonly used for local area networking of devices and Internet access, allowing nearby digital devices to exchange data by radio waves.
IP Certified	Waterproof (IPX7), dustproof (IP6X) & MIL-SPEC certified
Motherboard	The main Printed Circuit Board (PCB) placed inside the enclosure
Inlet Outlet Mesh	The filter caps are placed to restrict large-sized dust particles from entering the device.
ppm	Parts per million. It is a unit of measurement used when expressing a very dilute concentration level of pollutants in the air
ppb	Parts per billion. It is a unit of measurement used when expressing a very dilute concentration level of pollutants in the air
µg/m³	micrograms (one-millionth of a gram) per cubic meter. It is a unit of measurement used when expressing a very dilute concentration level of pollutants in the air.
mg/m³	Milligrams (one-thousandth of a gram) per cubic meter. It is a unit of measurement used when expressing a very dilute concentration level of pollutants in the air.

2. Safety

Certain safety precautions need to be taken before and during the operation & maintenance

DOs

- Read and understand the instruction manual and all other safety instructions before using the Pollusense.
- All necessary personal protective equipment (PPE) such as Gloves, Goggles, Shoes, helmets, etc. must be worn at all times by the engineer.
- Electrical connections must be checked before powering up the Pollusense.
- All necessary permissions are to be checked and met before placing the Pollusense at the desired location.
- Anti-static gloves must be used for any kind of troubleshooting inside the Pollusense.
- Always switch OFF the Pollusense for any cleaning or replacement activity and remove the power cable.
- After switching OFF the Pollusense, always wait for 1 minute before switching it ON.
- Make sure there are no cuts or joints, cracks, or abrasions on the cables or wires.

DON'Ts

- Don't run cords along the floor outdoors or let cords get twisted or tangled.
- Don't use temporary wiring.
- Don't provide power to the Pollusense without any voltage stabilizer(UPS).
- Don't place the Pollusense without performing the bench test.

3. Product Specifications

Pollusense™ is an industrial-grade multi-parameter mobile air quality monitor. Pollusense™ offers a wide range of air quality parameters to choose from. The range of available parameters consists of all the important Gases, Particulates, and for Industrial Field Surveys, EHS Monitoring, Leakage detection, Mining, STP, Landfills and much more. The Pollusense™ series is designed for easy and inexpensive maintenance and easy to carry use case.

Pollusense™ – comes with an on-device display to check the concentration of the parameter without being dependent on a computer or any external display.

Pollusense™ data is accessible via Oizom Air Quality Software, Envizom™ where various data visualization and data analytics are possible. Various alerts and notifications can be set based on this data for the industrial safety and environmental health safety of workers.

Based on the application, Oizom® offers solutions to monitor different essential parameters.



Figure 3.1 Schematic

3.1 Product Features

On-Device Display

Built-in Display to check the on-site concentration of the pollutants and unit of measurement without being dependent on a computer

Ultimate Durability

Waterproof (IPX7), dustproof (IP6X) & MIL-SPEC certified Nanuk 930 Case

Wide range of parameters

Compatible with a wide range of environmental parameters for Gases such as SO₂, NO₂, NO, H₂S, TVOC, CO, Cl₂, NH₃, CH₄, CH₂O, CO₂, and CH₃SH and Particulate Matter (PM₁, PM_{2.5}, PM₁₀, PM₁₀₀).

Temperature-Humidity-Pressure Monitoring

Built-in Temperature-Humidity-Pressure sensor in each Pollusense™ to use in advanced data processing algorithms for compensating any effect of temperature and humidity on the sensor output.

Real-time data transfer

Continuous Monitoring and real-time data transfer at configurable intervals.

Wireless Communications

Supports a wide range of wireless connectivity options like GSM, WiFi and LoRa Ethernet is also supported in wired communication.

Retrofit Mobility Design

Plug-and-play design for ease of implementation and mobile-ready

Over-The-Air Update

Automatic Firmware and Calibration update from a cloud without any onsite visit (available for GSM/Wifi/Internet-Over-Ethernet connectivity)

Internal Data Storage

In case of network losses, data is stored in internal 16GB memory which can provide data backup for up to 90 days.

Data Analytics Software

Advanced software to view data, analyze, integrate and create reports for actionable insights

Identity and Configuration

Each device carries its unique identity with geo-tagging through wireless configuration.

Weatherproof

Waterproof (IPX7), dustproof (IP6X) & MIL-SPEC certified

Dedicated Support

Skilled support team to assist users in problem-solving

3-level Calibration

Factory calibration, Laboratory calibration & Collocation Calibration in an ISO/IEC 17025 laboratory for zero and span calibration and provision of Onsite calibration.

3.2 Product identification

Every product is assigned a unique serial number before it is dispatched from the facility. This unique serial number can be found on the nameplate along with information about the product name/Model, power rating, year of mfg., weight of the Device, and certifications. The unique Device ID is very important and becomes crucial while communicating for any kind of support.

Device ID number: Each Device ID is unique. Example: OZ01S0001

Where OZ is your company initials, 01 is your number of order, S for Pollusense and 0001 is the Device Number specific to your order qty.

Model: This indicates the name of the Model. E.g.: Pollusense™.

Input Voltage: This indicates the power supply specifications for the Device.

E.g.: 100-240 VAC, 50/60 Hz.

24V DC, 2A

Type C: > 45W PD

Full Load Current: This indicates the maximum current that the device is designed to consume under particular conditions. E.g.: 2 A (2 Ampere current is the max. amount of current consumed.)

Approximate Weight: This indicates the approximate weight of the device which helps us to understand the exact placement of the device. e.g.: 9 kg

Year of Mfg: This indicates the year the device was manufactured. E.g: 2024

IP rating: This Ingress Protection rating indicates the defined levels of sealing effectiveness of electrical enclosures against intrusion from foreign bodies (tools, dirt, etc.) and moisture.

Made in India: This marking on the device indicates that the device's country of origin is India.

3.3 Sensor specifications

Multiple sensors with different measurement ranges can be integrated into the Device for different environmental parameters. Pollusense can cater up to 9 Gas Sensors & an All-in-1 PM Sensor. Below are the Pollusense™ parameters which Oizom® can offer.

Table 3.1 Pollusense™ Parameter Offering

ID	Parameter	Range (ppm)	Resolution (ppm)	Min. Det. (ppm)	Drift	Working Principle	Expected Sensor Life
OZSO2_2	Sulfur dioxide (SO2)	0-100	0.2	0.2	< 2% / Month	Electrochemical	2 Years
OZSO2_3	Sulfur dioxide (SO2)	0-2000	5	5	< 2% / Month	Electrochemical	2 Years
OZSO2_4	Sulfur dioxide (SO2)	0-20	0.01	0.01	< 2% / Month	Electrochemical	2 Years
OZNO2_2	Nitrogen Dioxide (NO2)	0-100	0.2	0.2	< 2% / Month	Electrochemical	2 Years
OZNO2_3	Nitrogen Dioxide (NO2)	0-500	0.5	0.5	< 2% / Month	Electrochemical	2 Years
OZNO2_4	Nitrogen Dioxide (NO2)	0-10	0.01	0.01	±50 ppb / Year	Electrochemical	1 Year
OZH2S_2	Hydrogen Sulfide (H2S)	0-50	0.05	0.05	< 2% / Month	Electrochemical	2 Years
OZH2S_3	Hydrogen Sulfide (H2S)	0-200	0.2	0.2	< 2% / Month	Electrochemical	2 Years
OZH2S_4	Hydrogen Sulfide (H2S)	0-2000	2	2	< 2% / Month	Electrochemical	2 Years
OZH2S_5	Hydrogen Sulfide (H2S)	0-10	0.005	0.005	< 2% / Month	Electrochemical	2 Years
OZCO_4	Carbon monoxide (CO)	0-50	0.05	0.05	< 2% / Month	Electrochemical	2 Years
OZCO_2	Carbon monoxide (CO)	0-100	0.1	0.1	< 2% / Month	Electrochemical	2 Years
OZCO_3	Carbon monoxide (CO)	0-1000	0.75	0.75	< 2% / Month	Electrochemical	2 Years
OZCO_5	Carbon monoxide (CO)	0-10	0.01	0.01	±100 ppb / Year	Electrochemical	1 Year
OZNO_2	Nitric Oxide (NO)	0-100	0.5	0.5	< 2% / Month	Electrochemical	2 Years
OZNO_3	Nitric Oxide (NO)	0-10	0.015	0.015	< 2% / Month	Electrochemical	2 Years
OZTVOC_1	TVOC	0-40	0.001	0.005	N.A.	PID	24 months

OZTVOC_2	TVOC	0-200	0.05	0.05	N.A.	PID	24 months
OZCL2_1	Chlorine (Cl2)	0-20	0.05	0.05	< 2% / Month	Electrochemical	2 Years
OZCL2_2	Chlorine (Cl2)	0 - 50	0.1	0.1	< 2% / Month	Electrochemical	2 Years
OZNH3_2	Ammonia (NH3)	0-100	0.3	0.3	< 2% / Month	Electrochemical	2 Years
OZNH3_3	Ammonia (NH3)	0-1000	2	2	< 2% / Month	Electrochemical	2 Years
OZNH3_4	Ammonia (NH3)	0-10	0.015	0.015	< 10% / Year	Electrochemical	2 Years
OZCH4_2	Methane (CH4)	50-10,00,000	1	50	N.A.	Electrochemical	2 Years
OZCH2O_1	Formaldehyde (CH2O)	0-10	0.05	0.05	< 2% / Month	Electrochemical	2 Years
OZCH2O_2	Formaldehyde (CH2O)	0-50	0.1	0.1	< 2% / Month	Electrochemical	2 Years
OZCO2_1	Carbon Dioxide (CO2)	0-5000	1	400	±5 ppm / Year	NDIR	2 Years
OZCH3SH_1	Methyl Mercaptan (CH3SH)	0-10	0.1	0.1	< 2% / Month	Electrochemical	2 Years
OZHCL_1	HCl	0-50	0.5	0.5	< 2% / Month	Electrochemical	2 Years
OZHCL_2	HCl	0-100	1	1	< 2% / Month	Electrochemical	2 Years
OZO3_2	Ozone (O3)	0-8	0.01	0.01	±20 ppb / Year	Electrochemical	1 Year
OZO2_1	O2	(0-25) %VOL	0.1 %VOL	0.1 %VOL	< 2% / Month	Electrochemical	2 Years
OZHC_1	Total Volatile Organic Compounds (VOC) / Hydrocarbon	0-20	0.001	0.005	N.A.	PID	24 months
OZPM_1	Suspended Particulate Matters with size less than 2.5µ (PM 2.5)	Upto 5000 µg/m3	0.1 µg/m3	1 µg/m3	N.A.	Optical Particle Counter	5000 hours
	Suspended Particulate Matters with size less than 10µ (PM10)				N.A.		
	Ultra Fine Particulate Matters with size less than 1µ (PM1)				N.A.		
	Total Suspended Particulates (TSP) (PM100)				N.A.		

TVOC Sensor Housing: 24 Months, TVOC Lamp is user replaceable: 5,000 hours

Expected Sensor Life can vary, subject to actual concentration on-site. In the interest of continued product improvement, we reserve the right to change design features and specifications without prior notification. The data contained in this document is for guidance only. Oizom® accepts no liability for any consequential losses, injury or damage resulting from the use of this document or the information contained within.

3.4 Technical Specifications

Table 3.2 Technical specifications

Processor	Quad-Core ARM Cortex A-72
Memory	2GB RAM, 16GB eMMC ROM
Internal Data Storage	Up to 90 days
Device Interface	On-device Display, APIs, Oizom WebApp
Display Specification	7-inch IPS with HDMI

Table 3.3 Sensing specifications

Target Gas	Refer Table 3.1
Gas sample mode	Active-Sampling
Warm-up time*	Upto 3 hours for gas monitoring Upto 15 min for PM monitoring
Response time (t90)	< 60 Seconds
Signal refresh rate	5 Seconds
Measuring Range	Refer Table 3.1
Accuracy	<±5%FS (at 20±5°C/ 50±20%RH)
Sensor life	Refer Table 3.1

* 30 min - if device has been turned off for < 24 hours;
3 hours - if device has been turned off for long hours

Table 3.4 Electrical specifications

Power Supply	AC: 100VAC- 240VAC 50/60Hz DC: 24V, 2A, USB Type C: > 45W PD
Average Power consumption	5 W
Wiring connections	Pre-wired supplied with 2m cable
PSU	24V, 2A output from either of the power inputs
Battery	12.8V 6 Ah

Table 3.5 Device Specifications

Size (HxWxD)	503 (L) x 406 (W) x 193 (H)
Weight	9 kg (Instrument weight)

Table 3.6 Communication specifications

Wireless Communications*	Global GSM 2G/3G/4G, WiFi (802.11 b/g/n)
Wired Communication*	Ethernet (Static IP / DHCP)

* Oizom is not liable in the case of on-site network or power loss.

Table 3.7 General Performance Specifications

Operation temperature	-20 to +60°C
Operation humidity	15 - 90%RH, non-condensing
Storage conditions	10 - 40°C
Weather Protection	Waterproof (IPX7), dustproof (IP6X) & MIL-SPEC certified

3.5 PSU (Power Supply Unit)

To provide power supply to the Device consisting of PSU with a specification of 24 V, 2 Amps output from either of the power inputs.

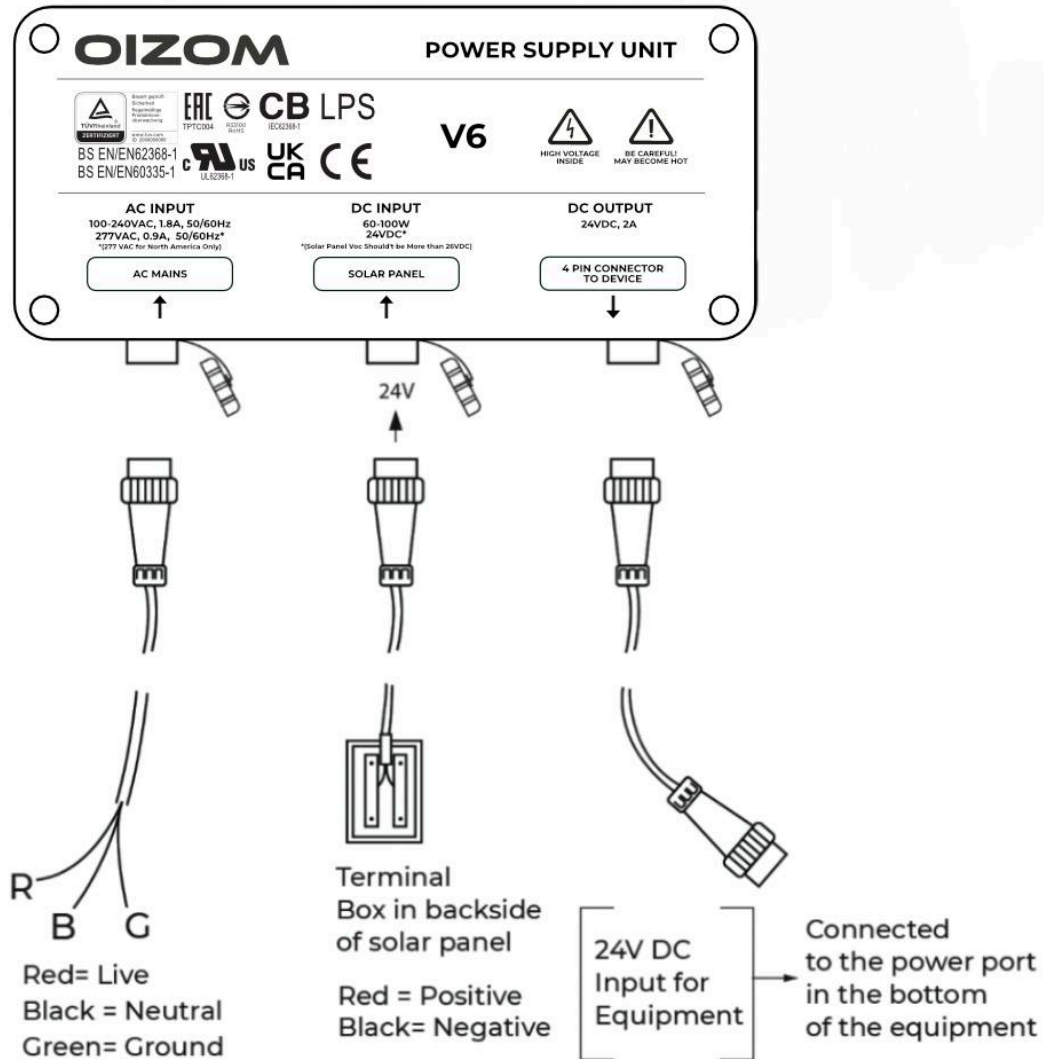

Figure 3.2 Power Supply Unit

4. Preparing Pollusense™ for use

4.1 Transportation

The stickers on the packaging box help us to make sure that Pollusense™ is taken care of during transportation to avoid any damage. Refer to the table below to understand the meaning of each symbol on the packaging box.







 <p>The goods inside are fragile and must therefore be handled with care to avoid breakage.</p>	 <p>This box is recyclable.</p>	 <p>The transport package shall be kept away from rain and be kept in dry conditions.</p>
 <p>For the duration of shipping/delivery/unpacking, the box should be upright.</p>	 <p>The box must not be stacked and should be loaded and carried around with lots of care.</p>	 <p>Do not step on the box.</p>

Figure 4.1 Packaging Stickers

If the box is tampered with or broken, contact the assigned Oizom Project team or its representative for support.

4.2 Prerequisites for Installation

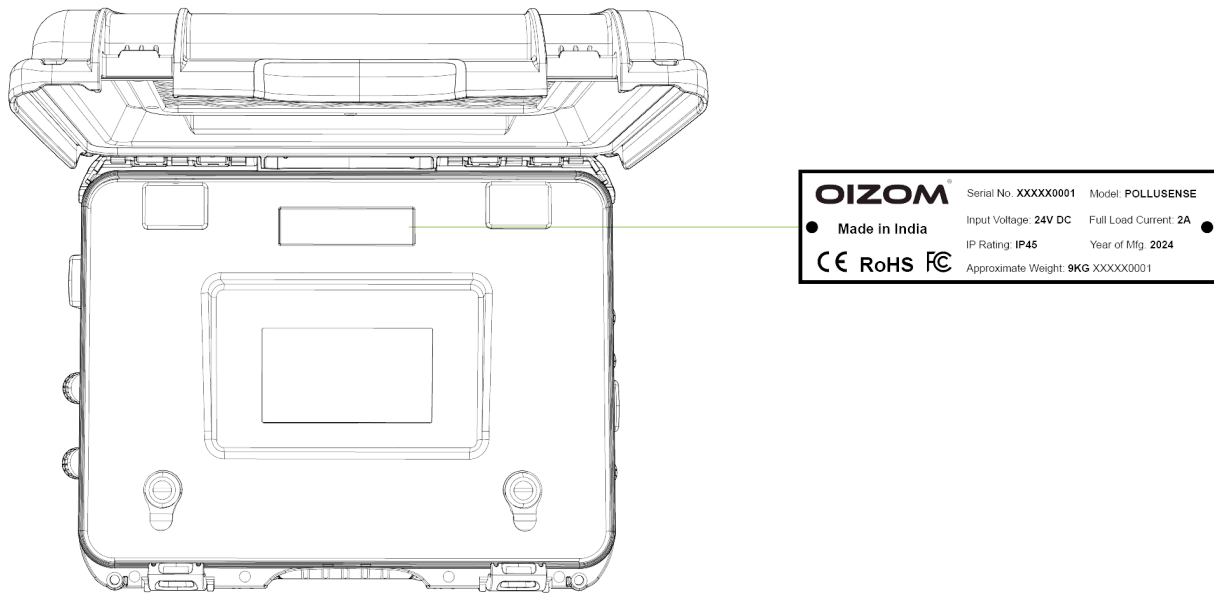

Figure 4.2: Information inside the Pollusense Case

Please read the information inside the Pollusense Case carefully before proceeding towards the Bench Test and On-Site survey

4.2.1 Unboxing

Unbox the package and take out the Pollusense. During unboxing make sure the mentioned arrow on the packaging should point to the sky.

The below-listed items are present in the box:

1. Pollusense™
2. Power Cables (AC + DC)
3. PSU
4. User Manual + Calibration Certificate + Warranty Certificate + Factory Acceptance Test (FAT) Report + Tax Invoice

As part of Planet Earth, we aim to reduce waste and increase efficiency, Oizom advises you to keep the recyclables out of the landfill, thus recycling the packaging box. If you are unsure about where to take your packaging box for recycling, search the website for your town, city, or community regarding waste, garbage, or recycling management for your area. Contact them and follow their instructions.

4.2.2 Identification of Components

Enclosure

The Waterproof (IPX7), dustproof (IP6X) & MIL-SPEC certified Nanuk 930 Case on its own is waterproof, dustproof, impenetrable and indestructible which makes it compatible with rugged locations and easy to carry.



Figure 4.3 Enclosure

Table 4.1 Purpose of Connectors

Connectors	Purpose
Power In	AC Power Cable
Power In	USB Type C

4.3 Initial Setup (Bench Test)

It is advisable to put Pollusense™ into operation before installing it. The following steps will guide you to step-wise initialization on a test bench. It is recommended to place the Pollusense on a flat surface devoid of any static charge. The Device must be placed horizontally so that the display of the Pollusense is visible on the top and the bottom view of the device is easily accessible for power connection.

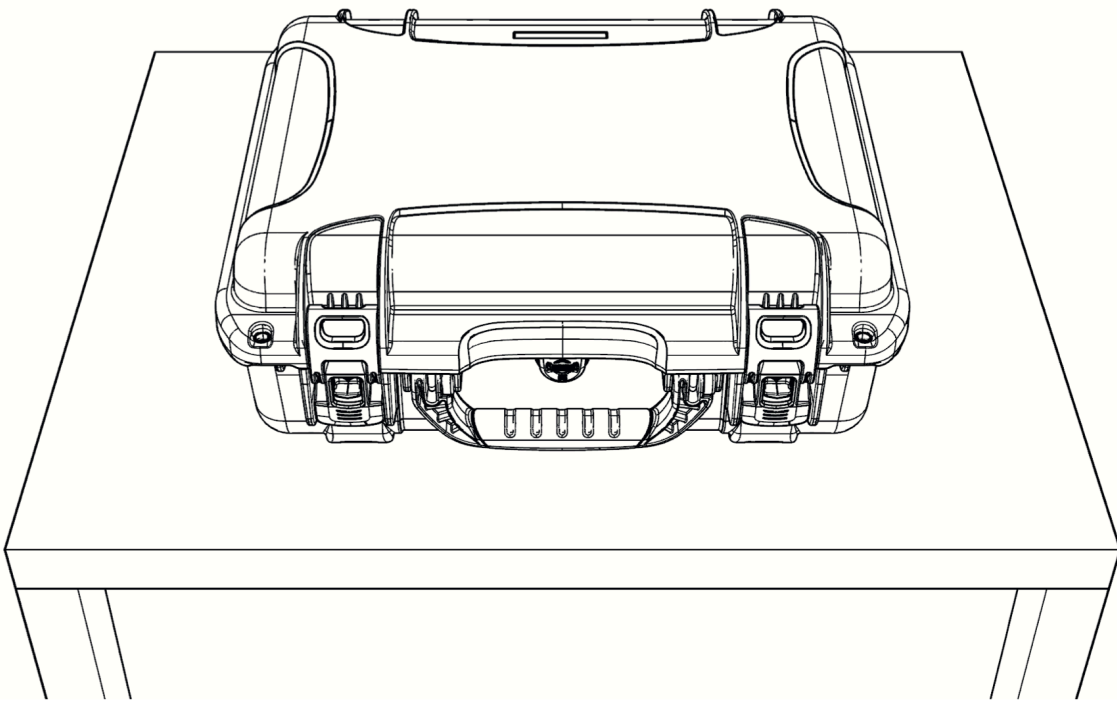

Figure 4.4 Pollusense for bench-test

4.3.1 Power Connection

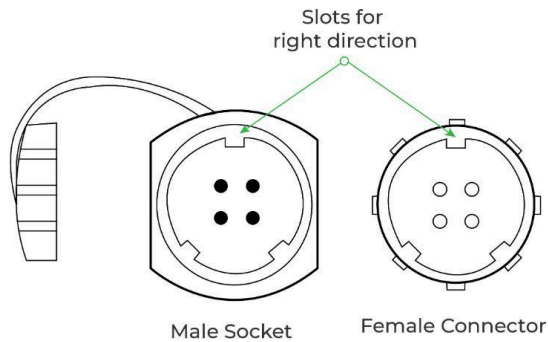

Figure 4.5 Identification of connectors

Step 1 Firstly AC-power cable needs to be connected to the AC power supply to 1st 3-pin connector of the PSU, then the 4-pin DC cable will be connected to the 3rd DC connector to the Pollusense Power-In connector.

Step 2 Check for the 3 slits on both the connectors. One of the 3 slits will be

wider than the other two. The widest slit on the female connector on the Device can be seen beneath the connector labels. To insert the male connector, match this slit with the one on the female connectors and gently insert it in with a little push. The connector must not be forced into the port by any means. Do not try to force the connector into the port by adjusting it in random circular motions. Doing so will damage the connector pin as well as Pollusense™.

Step 3 Once the connector is inserted, tighten the protection cover by rotating it in the clockwise direction.

The connectors provided are used for power and accessories. Users are advised to check for the connector labels and cable tags before any connection.

AC Power In Supply	Red: Direct (100V-240V AC) (50-60Hz) Black: Neutral Green: Earth
---------------------------	--

Note: Check cable tags before connecting any wires to the power source.

Now, you have connected the 4-pin power connector to the device, the other end needs to be connected to an AC power supply once an adapter plug is attached to the provided cable of the connector.

In case you fail to power the device, check the supplied AC voltage (in case of AC power input) using a Multimeter and ensure it is 100V-240V AC.

It is important to open the two latches with the latch key and place the nano-sim card inside the motherboard, before switching on the Pollusense

4.3.2 LED indications

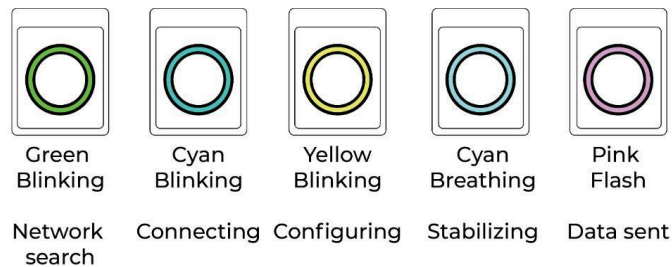

Figure 4.6 LED indications

To switch ON the Device, push the Power switch inside the case one time. To switch OFF the Device, push the power switch again one time. Before switching ON the Device, recheck all power cable connections. If you are restarting the unit, wait for at least a minute before switching ON.

The Power ON/OFF switch has an LED indication feature. Five different colours signify different modes of operation. Figure 4.6 describes the LED functions and their significance.

In case there is no LED indication on the Switch, It is mandatory to switch off the AC power supply and the device itself before opening the enclosure case internally.

4.3.3 Display

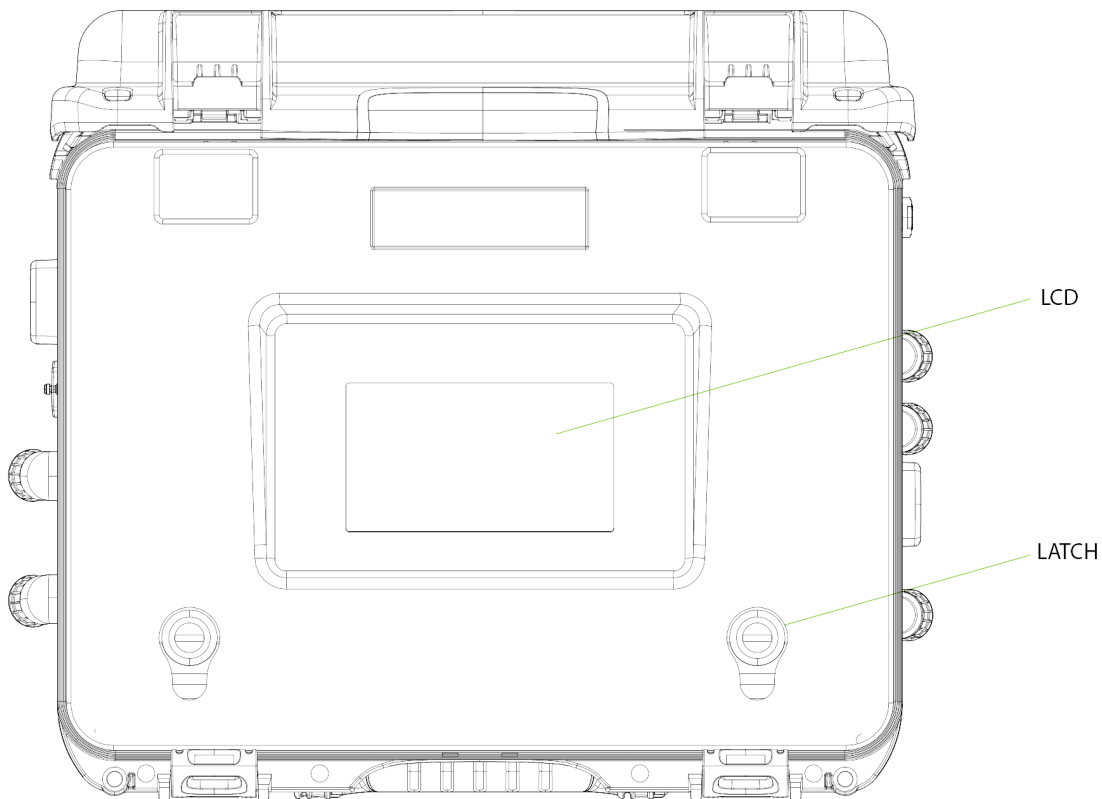

Figure 4.7 Display Location

Once the Pollusense is powered ON by pressing the switch, yellow blinking can be seen on the switch LED after 60-70 seconds. The yellow blinking will continue for about 20-30 seconds. The first data point will be displayed within 5 minutes of display initialization.

4.3.4 Connectivity

Pollusense is empowered with wireless communication protocols such as WiFi and GSM, these communication protocols can work together, simultaneously with the smart network management protocol.

The devices are compatible with fallback 2G, 3G, and 4G networks along with LTE.

To access the on-device data visualization tool, the Device should be powered ON.

There will be two conditions under which the Device will be:

Condition A

The Device is not connected to any existing WiFi or GSM Network. Under this condition, the Pollusense will be a hotspot. Any smart device can hence be connected to the Device. To establish connectivity, follow the steps:

- Step 1** In case the laptop is used, then the credentials will be:
SSID - [DEVICE ID/Serial No.] Eg. If the device ID/Serial No. allotted is BD03PS001, the SSID will be BD03PS001.
Password - 12345678
- Step 2** Open any web browser on your smart device and enter the following:
[DEVICE ID/Serial No.].local
Eg. if the device ID/Serial No. allotted is BD03PS001, enter <http://bd03ps001.local> Or 192.168.45.1
The IP address allotted to the device in the network
- Step 3** Enter the user credentials for the login page:
Email address - admin@oizom.com
Password - oizom@admin
- Step 4** The on-device software can now be accessed on the smart device



Figure 4.8 Open Case & Power Switch

Condition B

The Device is connected to an existing WiFi network. Under this condition, ensure that the smart device is connected to the same network. In case of external WiFi connectivity, you will have to use your any other smart device like a laptop or a cellphone

- Step 1** Open any web browser on your smart device and enter the following:
[Device ID].local
 Eg. if the device ID (Serial No.) allotted is BD03PS001, enter <http://bd03ps001.local> or the IP address allotted to the device in the network
- Step 2** Enter the user credentials for the login page:
 Email address - admin@oizom.com
 Password - oizom@admin
- Step 3** The on-device software can now be accessed

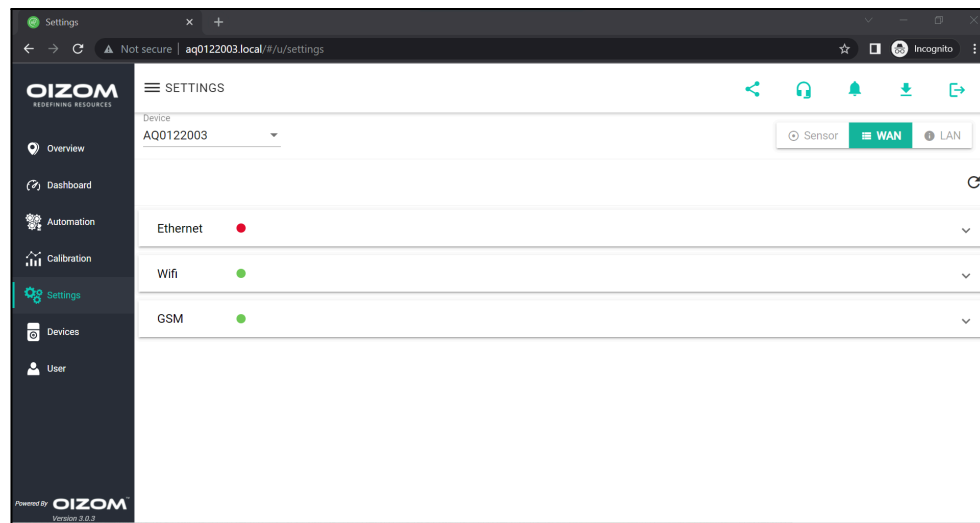

Figure 4.9 On-Device Data Visualization

Once connected, the user will have access to some basic modules. There will be 2 tabs under the **Settings** module:

1. Sensors - For enabling or disabling data of any sensor provided in the Device. This can be done with the help of a toggle.
2. WAN - Network configuration for GSM & WiFi

Following are the stepwise instructions for configuring the Device with your preferred communication protocol:

4.3.4.1 GSM

If the Pollusense is to be established on a GSM network, it should have a working nano SIM card, i.e. with an active data plan of 1 GB/Month placed inside. To insert the SIM card, the user needs to follow the following instructions:

- Step 1** Ensure that you have a working nano-SIM card that is activated by the carrier. Open the two latches with the key and insert the SIM on the motherboard
- Step 2** For replacing an existing SIM, gently remove the SIM by pressing it using your finger and then pulling it outwards.
- Step 3** Replace with a new SIM by pressing it inwards, make sure the SIM notch is facing internally and gently push it using your finger.
- Step 4** Put back the cap as it was placed earlier.
- Step 5** Select the Settings module on the on-device software and click on GSM. The Red dot shows that there is no connection established to the internet via GSM Network. This will be shown when no SIM card is inserted or there is no or poor internet connection or APN is not set.
- Step 6** Users can select from Manual or Automatic APN entries. In the case of manual APN, enter your APN of the SIM carrier.
- Step 7** Select Submit. The Green dot shows the connection is established.
- Step 8** Check for the latest data point in the Overview or Dashboard module

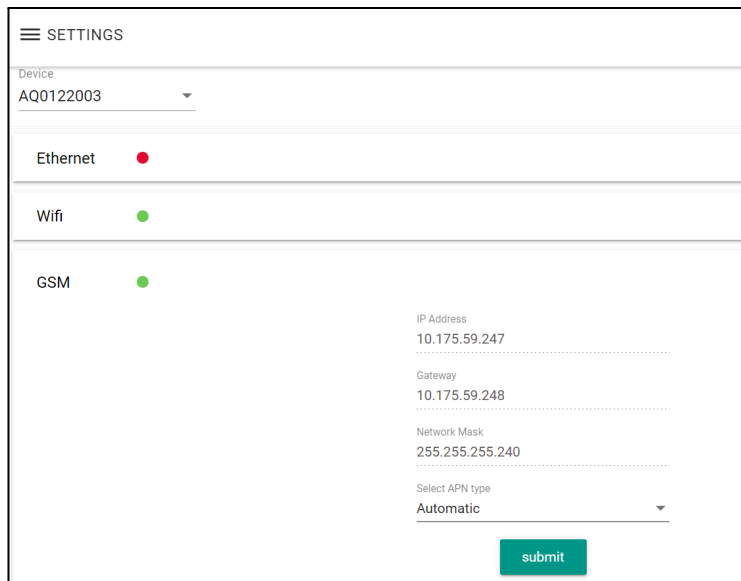

Figure 4.10 GSM configuration example

4.3.4.2 WiFi

- Step 1** Ensure the Device is in a zone where the WiFi signal is optimum. (To check the WiFi signal strength, you can connect any Mac, Windows device or tablet, or phone to the WiFi that you plan to connect the Device with and check

the WiFi signal strength through online websites/command prompt or Wifi Strength checker Application)

- Step 2** Select the Settings module on the on-device software and click on WiFi. The Red dot shows there is no connection established.
- Step 3** From the dropdown menu, select the Wifi SSID and enter the password of the WiFi network you wish to connect your Device with.
- Step 4** Enter Submit. The Green dot shows the connection is established.
- Step 5** Your Device is now connected to the preferred WiFi network. Check for the latest data point in the Overview or Dashboard module.

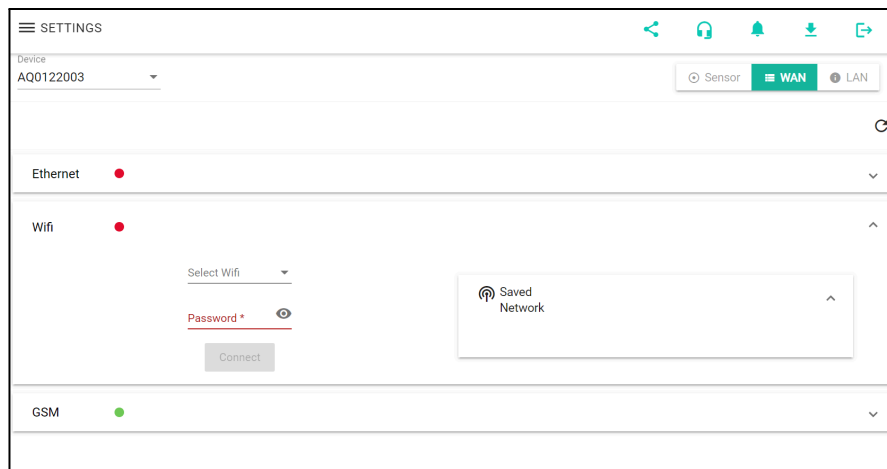

Figure 4.11 WiFi configuration

4.3.5 Data visualization

Data can be visualized on the On-device Data Visualization software or Envizom™. To check the data on the On-device software select the Overview or Dashboard module.

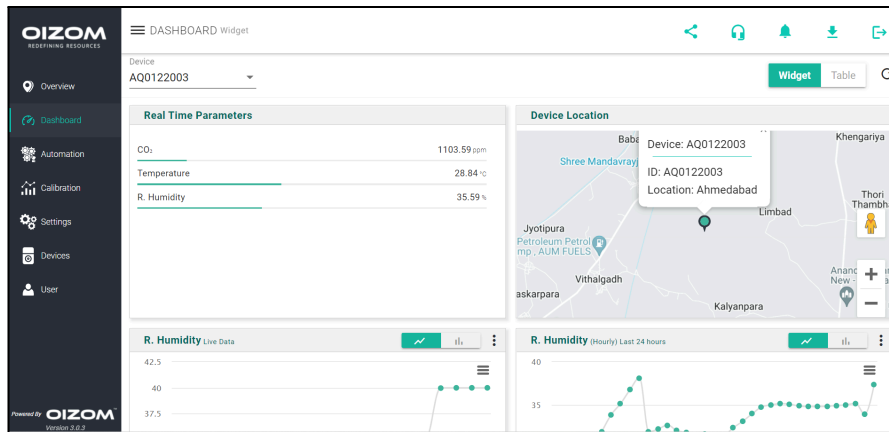

Figure 4.12 Dashboard module on On-device Software

Envizom™ is a Web application to visualize and analyze the data from the device. It can be accessed from any browser once the device is online on the internet. To go to Envizom™, type in your browser: <https://terminal.oizom.com> and hit Enter. Use your login credentials to access the application. The application is powered by several modules like Overview, Dashboard, Cluster, Display, Reports, Alerts, Analytics, User and Device management, etc.

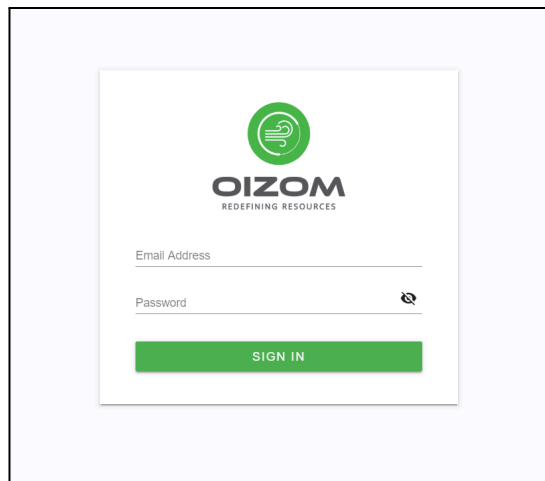

Figure 4.13 Login page-Envizom™

You can check out the **Envizom™** user guide for ease of understanding.

4.3.6 Sensor Configuration

The sensor can be configured on the On-device Data Visualization software.

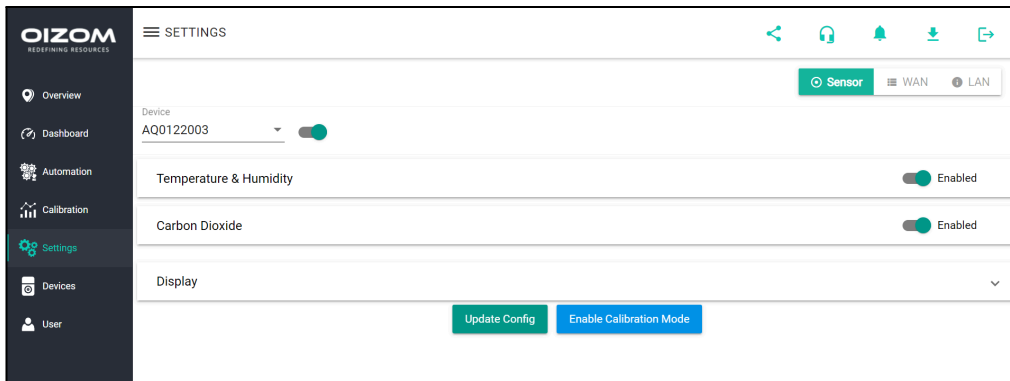

Figure 4.14 Sensor configuration

To enable or disable any sensor, click on the 'Settings' module from the on-device data visualization tool.

Click on the toggle to enable or disable as per the preference for any sensor. Click on Update Config to update the recent configuration. Check the next data point to validate the changes.

It is mandatory to switch off the AC power supply before opening the enclosure.

4.3.7 Device Configuration in Envizom™

Set location

From the Devices Module user can set the location of the device. Click on the Edit button then set the location by entering the lat long or by moving the pin on the provided map which will set the lat long accordingly and submit.

Configure device name

In the edit device section, users can set the Device Name/Label as per the specific requirement.

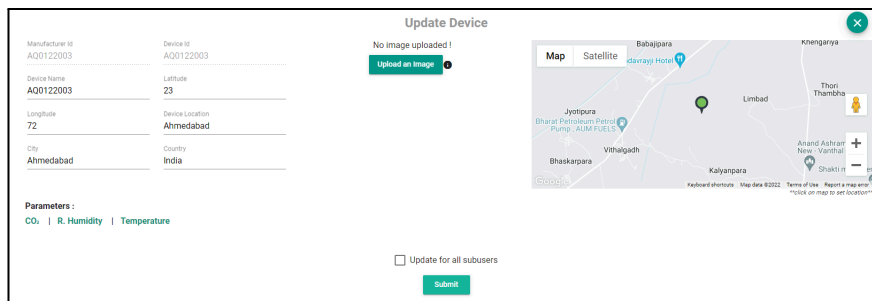

Figure 4.15 Devices Page-Envizom™

Configure units

For configuring the units go to the User module, then from the top right corner go to the Units section. Select Pollusense, It can be used to change the units of any parameter.

The screenshot displays the 'Units Setting' interface for an AQBOT device. It features a 'Device Type' dropdown set to 'AQBOT'. The main area is organized into three columns: 'Parameters', 'Limits', and 'Units'. Under 'Parameters', there are three rows: 'CO2', 'R. Humidity', and 'Temperature'. Each row has an edit icon in the 'Limits' column. In the 'Units' column, 'CO2' has radio buttons for '%w', 'mg/m³', and 'ppm' (selected). 'R. Humidity' has a radio button for '%' (selected). 'Temperature' has a radio button for '°C' (selected). At the bottom, there are 'Update' and 'Cancel' buttons.

Figure 4.16 User page-Envizom™

5. Instructions for location selection

5.1 Selecting location for Pollusense

- 1) Proper location selection is critical for optimizing data collection, it varies as per the purpose of the project. According to the USEPA QA handbook (vol II, Section 6.0 rev.1), the selection of locations should be based on monitoring purposes.
- 2) The Device should not be located adjacent to walls, buildings or trees as that might obstruct or distort the airflow.
- 3) The Device should be located away from local pollution sources like fire hydrants, sprinklers, standby generators, heat compressors, air exhaust, furnace or incinerator fumes, etc. so that the emissions from these sources will not affect monitoring.
- 4) The Device should be located away from absorbing or adsorbing surfaces. Some building materials can absorb pollutants or in some cases, PM₁₀ may get deposited on the leafy vegetation nearby. Hence, sites prone to the effects of absorption and adsorption should be avoided.
- 5) The Device should be located away from any physical interferences, e.g., location should be away from overhead high-voltage cables to prevent any electrical interference with the device.

- 6) Sites that are prone to chemical interference should be avoided, eg. roadside ozone monitoring may not be advisable since there are chances of interference from vehicular emissions.
- 7) The Device should not be located at road intersections (unless the intersection is a specific objective of the monitoring), instead, it should be located midway along the road. Air quality at intersections is generally unrepresentative and may be better or worse than the rest of the road, depending on congestion and airflow.
- 8) The Device should be preferably located at sites where there is an availability of existing structures to mount monitoring equipment as well as the availability of facilities such as electricity of sufficient rating, power, network connectivity, etc.
- 9) The Device should not be located at sites vulnerable to vandalism.

5.2 Placement of Pollusense

- 1) The Device should be at least 2 meters away from walls, buildings or trees to allow unrestricted airflow to the device.
- 2) The Device should be located at a height of 4-5 feet (1.2-1.5 meters) from the ground.
- 3) The sample inlets should not be within a confined space, in a corner, under or above a balcony in order to allow free airflow to the device. 2-2.5 m from the nearest vertical surface
- 4) The Device should be located in such a way that there is an open airflow in at least three of four quadrants, i.e., 270° around the inlet (180° if the device is placed at the side of a building).
- 5) The Device should be at least 25 m away from local pollution sources, e.g., domestic chimneys, standby generators, heat compressors, air exhaust, furnace or incinerator fumes, etc. especially if these sources are lower than the sampling point. With larger sources, the distance should be greater.
- 6) The Device should be kept more than 100 meters away from streets having traffic volumes exceeding 500 vehicles/day. Typical locations having negligible traffic are parks, malls or landscaped areas, etc.

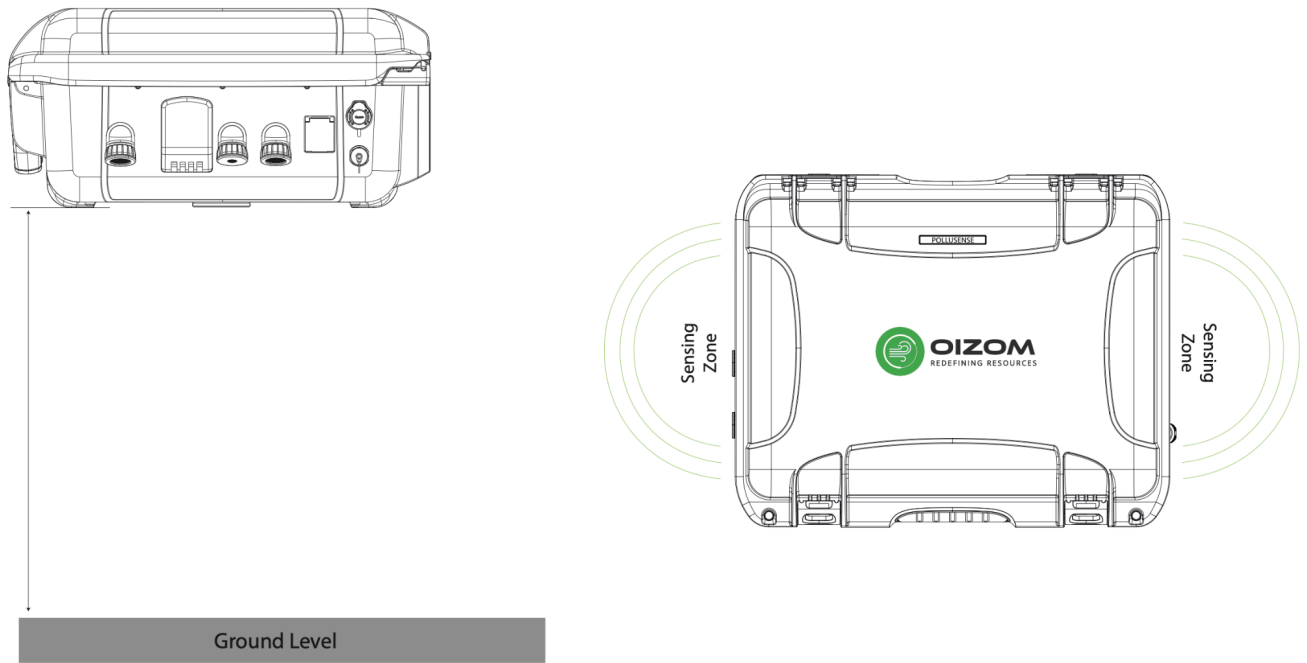

Figure 5.1 Selection criteria of Device placement

6. Operation and Maintenance

It is advisable that each operation measure is performed by a skilled/trained person.

6.1 Cleaning

While the Device will not need frequent maintenance, it is highly advisable to keep regular checks. Periodic cleaning is important to ensure optimum performance. Monthly or quarterly regular maintenance activity has to be carried out depending upon the surroundings. The activity includes cleaning the dust inlet and outlet mesh and general cleaning of the exterior. The below steps need to be followed for the cleaning of the device

6.1.1 Device

The device requires some basic cleaning using a brush, a soft cloth and a hand blower. The display must be cleaned so there is no issue in reading the concentration of parameters due to dust or water spots due to rain.

6.1.2 Sample inlets and outlets

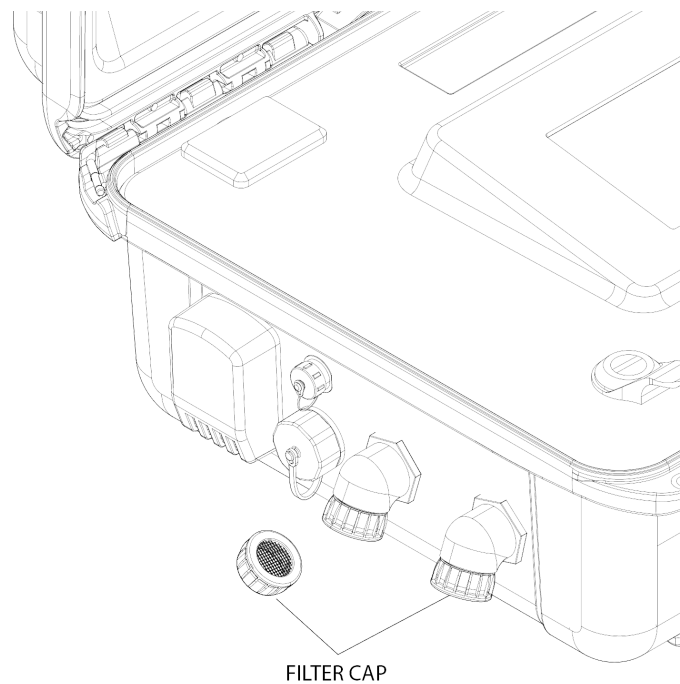

Figure 6.1 Cleaning of sample inlet and outlet

Filter caps are located on both the left and right sides of the Pollusense. Remove the filter caps by rotating them anticlockwise. Ensure that you remove the filter cap and not the nut and gasket. Clean the filter mesh with a soft cloth or a brush followed by blowing air into the filter mesh to remove dust or debris with a small hand blower. Once cleaned thoroughly, affix and rotate the filter cap clockwise to place it back.

6.2 Replacements

The Pollusense™ is designed for continuous use and requires minimal maintenance and calibration. Easy replacement steps can be followed by the user for continuous operation.

Replacement of any sensor should not take place when the Device is live and powered on. Always switch off the Device before sensor replacement or troubleshooting procedure.

If replacement of any other component is required, Oizom or its representative needs to be contacted for the same.

Every sensor has a limited lifespan with expected sensor life as per Table 3.1. The sensor life depends on the average pollutant concentration in the area. The sensors need to be replaced once their performance starts to deteriorate and the system starts giving unstable data.

7. Diagnosis/Debugging

Power and network availability are the prime checks in case of device failure. If the issue is still unresolved after remote diagnosis, on-site troubleshooting can be planned by an engineer. The below table lists the types of outcomes users can know based on the faults.

Table 7.1 List of outcomes

Parameter	Error Values (Device data)	Outcome
Gas Sensor	**After installation (or relocation)	Stabilizing (for the next 3 hours or 30 mins)
Gas Sensor	**If the Device is online after 24 hours due to power unavailability	Stabilizing (for the next 3 hours)
Gas Sensor	**If the Device is online within 24 hours due to a power unavailability	Stabilizing (for the next 30 mins)
Gas Sensor	Missing values for less than 24 hours	Possible Network issue
Gas Sensor	Missing values for more than 24 hours	Sensor might be loose internally / Under Troubleshooting

7.1 Reboot

- Device Restart is required when there is an issue of network availability on site.
- Sometimes, you can also experience that the sensor data is erroneous like constant 0 or constant value for unexpected time.
- Some of the errors/faults can be solved by simply rebooting the device.
- Simply push the switch and turn OFF the Device. Post 2 minutes, press the switch again to turn ON the Device.

Still experiencing issues with your Pollusense™?

Our remote support team is available for troubleshooting. Our system generates automated alerts in case of any malfunctioning and these alerts are received by our support team and issues are raised for our on-field well-trained service team who are equipped with tools and components provided by OIZOM. If you have any query or issue regarding the installation or functioning of our products, please reach out to our customer support team at the contacts below:

Contact No: +91-8866660083

Email ID: support@oizom.com