

# Table of contents

<b>1 General information</b>	<b>3</b>
1.1 General information	3
1.2 Health and safety instructions	4
1.3 Warning notices	4
1.4 User and operating requirements	5
1.5 Intended use	5
1.6 Disposal instructions	5
1.7 Certificates and approvals	5
<b>2 Introduction</b>	<b>6</b>
2.1 Introduction	6
2.2 Product identification	6
2.3 Scope of delivery	6
2.4 Measuring principle	7
<b>3 Commissioning</b>	<b>8</b>
3.1 Electrical installation	8
3.2 Serial interface	8
<b>4 Application</b>	<b>9</b>
4.1 Normal operation	9
4.2 Bypass installation	9
4.3 Support pipe installation	10
<b>5 Calibration</b>	<b>11</b>
<b>6 Malfunction and maintenance</b>	<b>12</b>
6.1 Return shipment	12
<b>7 Technical data</b>	<b>13</b>
7.1 Technical specifications	13
7.2 Outer dimensions	15
<b>8 Accessories</b>	<b>16</b>
8.1 TriBox3	16
8.2 TriBox mini	16
8.3 Flow cell	17
<b>9 Warranty</b>	<b>18</b>
<b>10 Technical support</b>	<b>19</b>
<b>11 Contact us</b>	<b>20</b>
<b>12 Index</b>	<b>21</b>
<b>13 Appendix</b>	<b>22</b>
13.1 CE declaration of conformity	22
13.2 Modbus RTU	23

# 1 General information

## 1.1 General information

Welcome to TriOS.

We are pleased that you have chosen our ORP sensor.

The TORP is a sensor for measuring the redox potential that communicates via the digital Modbus RTU protocol. It is characterized by low maintenance and easy integration with TriBox controllers via plug-and-play.

In this manual you will find all the information about TORP that you need for commissioning. Technical specifications as well as detection limits and dimensions can be found in chapter 7.

Please note that the user is responsible for complying with regional and national regulations for the installation of electronic devices. Any damage caused by incorrect use or unprofessional installation is not covered by the warranty.

All sensors and accessories supplied by TriOS Mess- und Datentechnik GmbH must be installed and operated in accordance with TriOS Mess- und Datentechnik GmbH specifications. All parts have been designed and tested according to international standards for electronic instruments. The device complies with international standards for electromagnetic compatibility. Please use only original TriOS accessories and cables to ensure smooth and professional use of the devices.

Read this manual carefully before using the device and keep it for future reference. Before using the sensor, make sure that you have read and understood the safety precautions described below. Always ensure that the sensor is operated correctly. The safety precautions described on the following pages are intended to ensure problem-free and correct operation of the device and the associated accessories and to prevent you, other persons or devices from being harmed.

### **NOTICE**

**If translations differ from the original German text, the German version is binding.**

#### Copyright notice

All contents of this manual, in particular texts, photographs and graphics, are protected by copyright. Unless expressly indicated otherwise, the copyright lies with TriOS Mess- und Datentechnik GmbH. Persons who violate the copyright are liable to prosecution in accordance with § 106 ff of the Copyright Act and will also be warned and liable to pay compensation.

## 1.2 Health and safety instructions

This manual contains important information on health and safety regulations. This information is marked in accordance with the international specifications of ANSI Z535.6 (“Product safety information in product manuals, instructions and other collateral materials”) and must be followed. The following categories are distinguished:

### **▲ DANGER**

**Danger / Will cause serious injury or death**

### **▲ WARNING**

**Warning / May cause serious injury or death**

### **▲ CAUTION**

**Caution / May cause moderate injury**

### **NOTICE**

**May lead to material damage**



#### **Tip / Useful information**

#### **Electromagnetic waves**

Devices that emit strong electromagnetic waves can influence the measurement data or cause the sensor to malfunction. Avoid operating the following devices in the same room as the TriOS sensor: cell phones, cordless phones, transceivers or other electrical devices that generate electromagnetic waves.

## 1.3 Warning notices

#### **General notices:**

- The material resistance should be tested for each application.
- Do not cut, damage or modify the cable. Ensure that there are no heavy objects on the cable and that the cable does not kink. Ensure that the cable does not run close to hot surfaces.
- If the sensor cable is damaged, it must be replaced with an original part by TriOS Mess- und Datentechnik GmbH customer support.
- Never attempt to disassemble or modify any part of the device unless expressly described in this manual. Inspections, modifications and repairs may only be carried out by the device dealer or by qualified specialists authorized by TriOS.
- Devices from TriOS Mess- und Datentechnik GmbH comply with the highest safety standards. Repairs to the devices (which include the replacement of the connection cable) must be carried out by TriOS Mess- und Datentechnik GmbH or an authorized TriOS workshop. Incorrect, improper repairs can lead to accidents and injuries.

**NOTICE**

**TriOS does not guarantee the plausibility of the measured values. The user is always responsible for monitoring and interpreting the measured values.**

## 1.4 User and operating requirements

The TORP sensor was developed for use in industry and science. The target group for operating the TORP is technically experienced specialist personnel in companies, sewage treatment plants, waterworks and institutes.

The application often requires the handling of hazardous substances. We assume that the operating personnel are familiar with the handling of hazardous substances due to their professional training and experience. In particular, the operating personnel must be able to correctly understand and implement the safety markings and safety instructions on the packaging and in the package inserts of the test kits.

## 1.5 Intended use

The TORP is intended exclusively for measuring the redox potential in aqueous solutions. This means that the TORP is a submersible sensor that is used under water or in conjunction with flow-through cells. Please observe the technical data of the sensor. Any other use is considered improper.

According to current scientific knowledge, the device is safe to use if it is handled in accordance with the instructions in this operating manual.

**NOTICE**

**Damage caused by improper use is excluded from the warranty.**

## 1.6 Disposal instructions

At the end of its service life or useful life, the device and its accessories can be returned to the manufacturer (see address below) for disposal in an environmentally friendly manner. Proof of prior professional decontamination must be provided in the form of a certificate. Please contact us before returning the device for further details.

Address of the manufacturer:

TriOS Mess- und Datentechnik GmbH  
Bürgermeister-Brötje-Str. 25  
26180 Rastede  
Rastede, Germany  
Phone: +49 (0) 4402 69670 - 0  
Fax: +49 (0) 4402 69670 - 20

## 1.7 Certificates and approvals

The product meets all requirements of the harmonized European standards. It therefore fulfills the legal requirements of the EU directives. TriOS Mess- und Datentechnik GmbH confirms the successful testing of the product by affixing the CE mark (see appendix).

## 2 Introduction

### 2.1 Introduction



The TORP sensor for measuring the redox potential from the eCHEM sensor product range is an electrochemical sensor for measuring in aqueous solutions. This digital sensor is a submersible sensor that is used under water or in conjunction with flow-through cells. It measures the redox potential at a gold electrode against an Ag|AgCl|Cl reference electrode.

### 2.2 Product identification

All TriOS Mess- und Datentechnik GmbH products are provided with a product label that clearly shows the product designation.

There is also a type plate on the device with the following information, which you can use to clearly identify the product:

#### Type plate

Serial number	Serial No <b>07100000</b>	
Product type	Type <b>TORP</b>	
Power supply	Sensor Power 12 – 24 VDC ± 10 % / 0.2 W	
Interface	Sensor Interface RS-485	

The nameplate also contains the product barcode, the TriOS Optical Sensors logo and the CE quality mark.

Please note that the specifications given here are for illustrative purposes only and may vary depending on the product version.

### 2.3 Scope of delivery

The delivery includes the following components:

- Part number 80S600020 eCHEM TORP with fixed cable 0.5 m

Optional:

- Item number 80S600010 eCHEM TORP with fixed cable 2 m
- Item number 80S600000 eCHEM TORP with fixed cable 10 m

Accessories (if applicable):

- FlowCell
- Adapter for pool edge attachment
- Controller

Keep the original packaging of the device for possible return shipment for maintenance or repair purposes.

## 2.4 Measuring principle

The redox sensor measures the ability of an aqueous solution to oxidize or reduce other substances. The measuring principle is based on the measurement of the electrochemical potential (potentiometry), which is generated by the redox reaction at an electrode.

Typically, this is measured between a precious metal electrode (gold for TORP) and a reference electrode (for TORP: Ag|AgCl|Cl reference electrode).

The sensor has a measuring range of -1000 mV...+1000 mV. Measured values towards the positive end of the measuring range indicate a strong oxidizing effect of the measuring solution, whereas a reducing effect is present in the negative range.

## 3 Commissioning

This chapter covers the commissioning of the TORP up to the first function test. Please pay particular attention to this section and follow the safety instructions to protect the product from damage and yourself from injury.

Before putting the sensor into operation, make sure that it is securely fastened and that the cables are connected correctly.

### 3.1 Electrical installation

#### NOTICE

**The sensor can be operated with 12-24 VDC.**

Fixed cable with M12 industrial plug

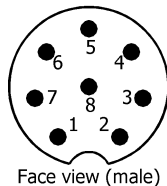

Face view (male)

1. RS-485 A
2. RS-485 B
3. Do not connect
4. Do not connect
5. Do not connect
6. Do not connect
7. GROUND (power + ser. interface)
8. POWER (12-24 VDC)

#### NOTICE

**Ensure the correct polarity of the supply voltage, otherwise the sensor may be damaged.**

Cable lengths

Cable lengths of 0.5 m (standard), 2 m and 10 m are available.

### 3.2 Serial interface

The serial interface of the sensor is an RS-485 interface and must be configured as follows (9600/8-N-1):

- Baud rate: 9600 bps
- Data bits: 8
- Stop bits: 1
- Parity: none
- Flow control: none

The protocol used is Modbus RTU.

The sensor is ready for commissioning as soon as the mounting of accessories has been completed, it is connected to a control device and the configuration has been completed.

## 4 Application

The TORP sensor is used for long-term monitoring and control of processes as well as for limit value control. Possible areas of application include water and wastewater treatment, coalgulation and flocculation processes and use in acid/base neutralization systems.

The sensor can be operated with the TriOS controllers (TriBox3 and TriBox mini). Notice for correct installation can be found in the respective controller manual.

### 4.1 Normal operation

In normal operation, the TORP is used as a submersible sensor and should be immersed at least so far that the black sensor head is completely surrounded by medium. Otherwise, measurement fluctuations may occur.

As soon as the sensor is connected to the power supply, three LED lights (blue, green and red) appear one after the other in the upper sensor area and it starts measuring. Only the green and red lights are relevant for the operation of the TORP.

LED	LED Description
Green permanent	Normal operation - the sensor is measuring
Red permanent	Hardware error

Depending on the application, the TORP should be validated at regular intervals with a standard solution (460-480 mV) to check the measurement results.

TORP sensors are considered consumables and therefore have a limited lifetime, depending on the user's application. Under normal conditions, a typical lifetime would be approximately one year. The life of the TORP can be extended by regular cleaning.

### 4.2 Bypass installation

In addition to submersible operation, the TORP can also be operated in bypass mode.

The sensor is installed in a bypass installation using a suitable TriOS flow cell. This is designed as a modular system and allows the process to be adapted or expanded as required.



Flow cell for eCHEM sensors

## 4.3 Support pipe installation

TriOS offers two adapters for the TORP sensor for installation in existing pipe systems:

- NPT1 adapter ZM46 (incl. lock nut ZM13)
- G1 adapter ZM41 (incl. lock nut ZM13)

### Assembly diagram

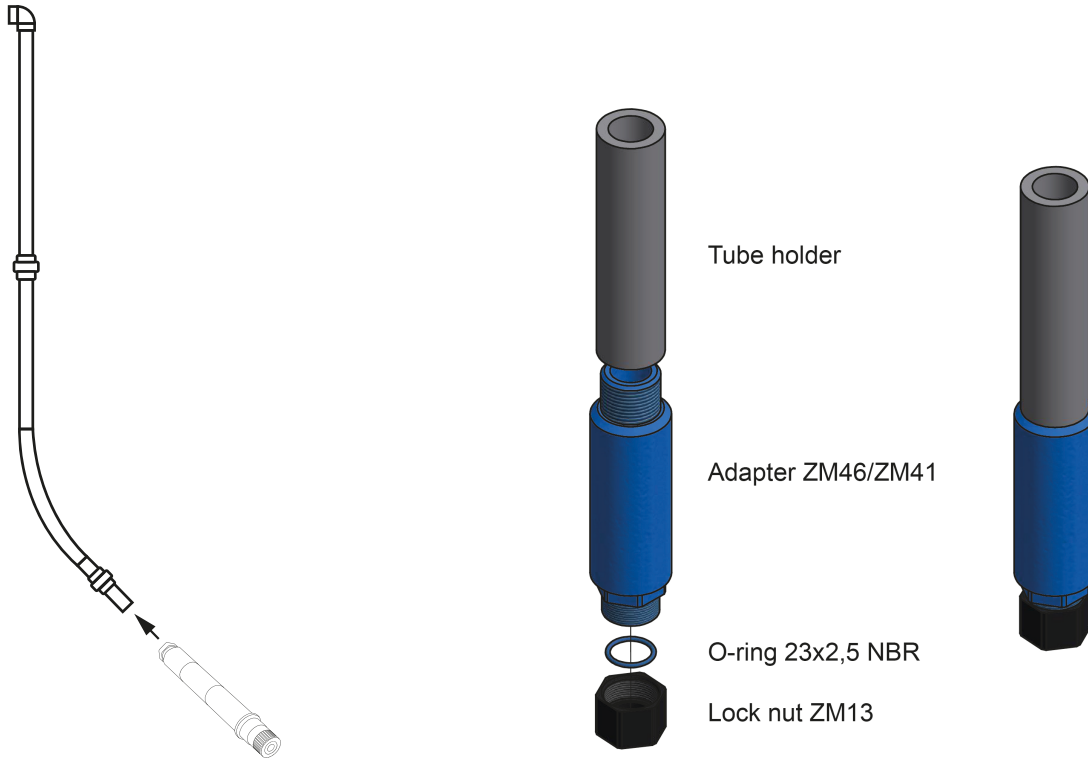

1. Feed the sensor cable through the adapter from the side onto which the screw cap will later be screwed (short thread).
2. Pull the complete cable through and push the sensor into the adapter as far as it will go (up to the guide obstacle).
3. Secure the sensor with the fastening cap.
4. The sensor and adapter can now be installed in the holder tube.

## 5 Calibration

Calibration of the sensor is not necessary. It is sufficient to carry out a validation with a standard solution (e.g. 460-480 mV).

## 6 Malfunction and maintenance

In the event of malfunctions, check all components for damage or defects. If necessary, check all connections and joints. Schedule regular maintenance checks to inspect the sensor for signs of wear, corrosion or damage.

As a rule, the sensor requires only minimal maintenance. However, in applications that cause heavy soiling of the sensor, the sensor should be serviced more frequently.

- The sensor should always be kept clean. If there is a biofilm on the sensor, this can lead to measurement errors.
- If possible, mechanical impact on the sensor should be avoided.

### NOTICE

**Do not disassemble the sensor for cleaning and maintenance purposes.**

### 6.1 Return shipment

Please note the procedure for your return.

If you wish to return the sensor or the device, please contact technical support first. To ensure a smooth return process and to avoid incorrect shipments, every return shipment must first be reported to technical support. You will then receive a numbered RMA form, which you must complete in full, check and return to us.

Please stick this form with the number clearly visible on the outside of the return package or write it in large letters on the packaging. This is the only way your return can be correctly assigned and accepted.



**Please note! Returns without an RMA number cannot be accepted and processed!**

Please note that the sensor or the device must be cleaned and disinfected before shipping.

Use the original packaging to ensure that the goods are sent undamaged. If this is not available, ensure that safe transportation is guaranteed and that the sensors are secured with sufficient packing material.

## 7 Technical data

### 7.1 Technical specifications

<b>Application</b>	Long-term monitoring and limit value control of processes; water treatment
<b>Measurement technology</b>	Redox electrode
<b>Measuring principle</b>	potentiometry
<b>Parameters</b>	Oxidation-reduction potential
<b>Applied standard</b>	DIN EN ISO 27888:1993
<b>Measuring range</b>	$\pm 1000$ mV
<b>Resolution</b>	0.01 mV
<b>Calibration</b>	Calibration of the sensor is not necessary. It is sufficient to carry out a validation with a standard solution (e.g. 460-480 mV).
<b>Smallest measuring interval</b>	$\geq 2$ sec
<b>Temperature compensation</b>	No
<b>Turbidity compensation</b>	No
<b>Data logger</b>	No

<b>Interface</b>	<b>digital:</b>	RS-485, Modbus RTU
	<b>analog:</b>	-
<b>Power supply</b>	12-24 VDC ( $\pm 10$ %)	
<b>Optical display</b>	Status LED	
<b>Connection</b>	8-pin M12 plug	
<b>Sensor cable</b>	0.5 m, 2 m and 10 m	

<b>Housing material</b>	PPS, PET, NBR	
<b>Dimensions (L x Ø)</b>	~180 mm x 27 mm	~ 7.1 " x 1.06 "
<b>Weight</b>	110 g	0.243 lbs

<b>Operating conditions</b>	<b>Temperature:</b>	0° C...+100 °C	32...212 °F
	<b>Fixed cable:</b>	3 bar	43.5 psi
	<b>Flow unit:</b>	1 bar at 2...4 L/min	14.5 psi at 2...4 L/min
<b>Protection class</b>		IP68	NEMA 6P

<b>Maintenance effort</b>	< 0.5 h/month typical
<b>System compatibility</b>	TriBox3, TriBox mini, Modbus RTU
<b>Warranty</b>	1 year (EU & USA 2 years) on electronics; wearing parts are excluded from the warranty

<b>Accessories (optional)</b>	<b>Cables:</b>	Extension cable 2 m, 10 m
	<b>Controller:</b>	TriBox3, TriBox mini
	<b>Fittings:</b>	FC eCHEM flow cell

7.2 Outer dimensions

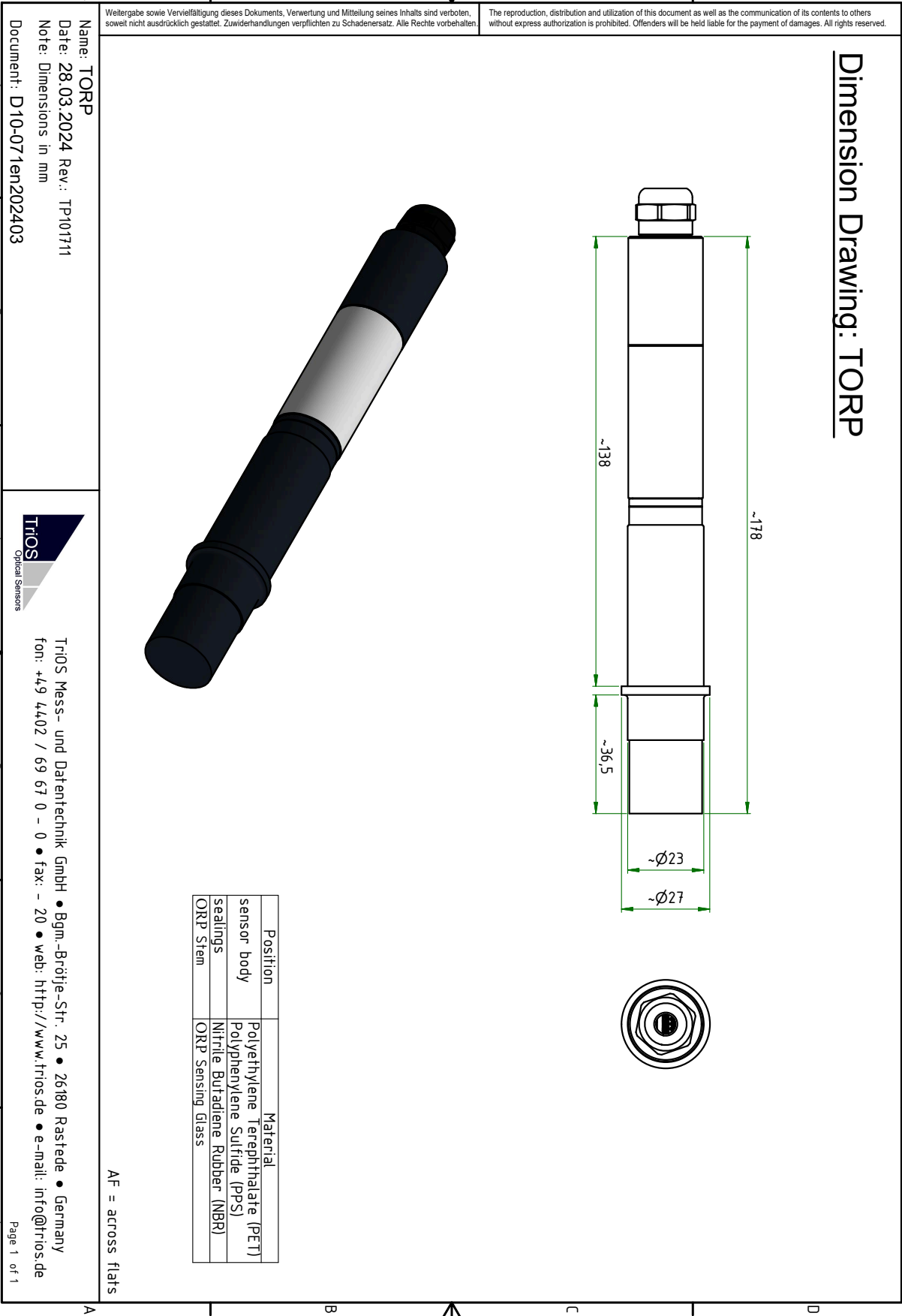

## 8 Accessories

### 8.1 TriBox3

Digital 4-channel display and control unit with integrated solenoid valve for compressed air control

TriBox3 is a measuring and control system for all TriOS sensors. The device offers 4 sensor channels with selectable RS-232 or RS-485 function. In addition to Modbus RTU, various other protocols are available.

A built-in valve allows the use of compressed-air cleaning for the sensors. The TriBox3 also offers various interfaces, including an IEEE 802.3 Ethernet interface, an IEEE 802.11 b/g/n interface, a USB port and 6 analog outputs (4...20 mA). An integrated relay can be used to trigger alarms or control external devices. Low power consumption, a robust aluminum housing and a range of interfaces makes it suitable for all applications in environmental monitoring, drinking water, wastewater treatment plants and many other areas.



### 8.2 TriBox mini

Digital 2-channel controller

Die TriBox mini is an controller with two digital sensor inputs and two 4...20 mA outputs and represent a cost-effective alternative to analog measuring points.

The TriBox mini is compatible with all TriOS sensors.

All stored measured values and diagnostic data can be read out via an integrated web browser.



## 8.3 Flow cell

### Flow cell for eCHEM sensors

The flow cell specially developed for the eCHEM series is used for bypass installations of the eCHEM sensors manufactured by TriOS. The measuring medium is fed through the cell via an inflow and thus enables reagent-free measurement outside the process. The flow cells are based on a modular system that can be expanded with additional modules.



## 9 Warranty

The warranty period for our devices within the EU and the USA is 2 years from the date of invoice. Outside the EU it is 1 year. Excluded from the warranty are all normal consumables (depending on the product, e.g. light sources or windows).

The guarantee is subject to the following conditions:

- The appliance and all accessories must be installed as described in the relevant manual and operated in accordance with the specifications.
- Damage caused by contact with aggressive and material-damaging substances, liquids or gases, as well as transport damage, are not covered by the guarantee.
- Damage caused by improper handling and use of the appliance is not covered by the warranty.
- Damage caused by modification or unprofessional attachment of accessories by the customer is not covered by the warranty.

### **NOTICE**

**Opening the device will void the warranty!**

## 10 Technical support

If you have a problem with a TriOS sensor / a TriOS device, please contact TriOS technical support.

We recommend sending in sensors every 2 years for maintenance and calibration. To do this, please request an RMA number from technical support.

### Contact technical support:

E-mail: support@trios.de  
Phone: +49 (0) 4402 69670 - 0  
Fax: +49 (0) 4402 69670 - 20

To enable us to help you quickly, please send us the sensor ID number (serial number with 8 digits, consisting of letters and numbers, e.g. 6700003F) by e-mail.

## 11 Contact us

We are constantly working on improving our devices. Please visit our website for the latest news.

If you have found a fault in one of our devices or programs or would like additional functions, please contact us:

Technical Support:	<a href="mailto:support@trios.de">support@trios.de</a>
General questions/sales:	<a href="mailto:sales@trios.de">sales@trios.de</a>
Website:	<a href="http://www.trios.de">www.trios.de</a>

**TriOS Mess- und Datentechnik GmbH**

Bürgermeister-Brötje-Str. 25

26180 Rastede

Rastede, Germany

Telephone

+49 (0) 4402 69670 - 0

Fax

+49 (0) 4402 69670 - 20

# 12 Index

## C

Calibration.....	11
Certificates and approvals.....	5
Contact us.....	20
copyright.....	3
customer support.....	4

## D

disposal.....	5
---------------	---

## E

Electromagnetic waves.....	4
experienced specialist personnel.....	5

## G

gold electrode.....	6
---------------------	---

## H

Health and safety instructions.....	4
-------------------------------------	---

## I

Intended use.....	5
-------------------	---

## O

operating requirements.....	5
-----------------------------	---

## P

Product identification.....	6
-----------------------------	---

## R

redox potential.....	3
reference.....	6
Return shipment.....	12

## S

Scope of delivery.....	6
------------------------	---

## T

Technical support.....	19, 20
type plate.....	6

## V

validated.....	9
validation.....	11, 13

## W

Warning notices.....	4
Warranty.....	18
wastewater treatment.....	9

# 13 Appendix

## 13.1 CE declaration of conformity

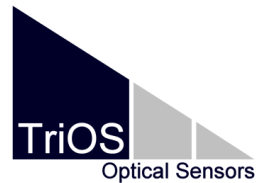

Hersteller/Manufacturer/Fabricant: TriOS Mess- und Datentechnik GmbH  
 Bürgermeister-Brötje-Str. 25  
 D- 26180 Rastede

### Konformitätserklärung Declaration of Conformity Déclaration de Conformité

Die TriOS GmbH bescheinigt die Konformität für das Produkt  
 The TriOS GmbH herewith declares conformity of the product  
 TriOS GmbH déclare la conformité du produit

Bezeichnung Product name Désignation	<b>TORP</b>
Typ / Type / Type	-
Mit den folgenden Bestimmungen With applicable regulations Avec les directives suivantes	2014/30/EU EMV-Richtlinie 2011/65/EU RoHS-Richtlinie + (EU) 2015/863 + (EU) 2017/2102
Angewendete harmonisierte Normen Harmonized standards applied Normes harmonisées utilisées	EN IEC 61326-1:2021 EN 61010-1:2010 +A1:2019 +A1:2019/AC:2019 EN IEC 63000:2018
Datum / Date / Date	Unterschrift / Signature / Signature
23.05.2024	 R. Heuermann

D05-071yy202405

Seite 1 von 1

## 13.2 Modbus RTU

### TORP Modbus RTU

Firmware v1.0.8

#### Serial interface

The configuration of the serial port for the serial interface (RS-485) is (9600, 8N1):

- Baud rate: 9600 bps
- Data bits: 8
- Stop bits: 1
- Parity: none

#### Data types

Data type name	register	format
Bool	1	false: 0x0000, true: 0xFF00
Uint8	1	8-bit unsigned integer. Value range: 0x0000 - 0x00FF
Uint16	1	16-bit unsigned integer. Value range: 0x0000 - 0xFFFF
Uint32	2	32-bit unsigned integer. Value range: 0x00000000 - 0xFFFFFFFF
Float	2	IEEE 754 32-bit floating point number
Char[n]	$\left[ \frac{n}{2} \right]$	ASCII character string with n characters
Uint16[n]	n	Field of n 16-bit integers (cf. Uint16)
Float[n]	2n	Field of n floating point numbers (cf. Float)

#### Functions

TORP supports the following Modbus functions:

Name	Name Code	Description / Use
Reading multiple registers	0x03	Reading out the serial number, configuration, firmware version, calibration and measurement data
Writing several registers	0x10	Write configuration.
Write single register	0x06	Triggering a measurement or a self-calibration process.
Report slave ID	0x11	Read serial number and firmware version.

#### Default slave address

The factory default setting for the slave address is 22 (0x16).

## Read / write multiple registers (0x03 / 0x10)

The R/W column describes the access restrictions for the registers. An 'R' means that it can be read (0x03), a 'W' means that it can be written (0x10).

### Example:

R	Read only, no writing.
R/W	Read and write.

## Modbus register assignment

Notice: The configuration registers should be written to as rarely as possible and especially not in every measurement cycle, as otherwise the flash memory may be damaged.

Name	R/W	Address	Data type	Data type Description
Modbus slave ID	R/W	0	Uint16	The Modbus slave ID of this device.
Measurement timeout	R	1	Uint16	The timeout in [10-1 s] of an ongoing measurement process.
Serial Setting - Baud rate	R/W	2	Uint16	<ul style="list-style-type: none"> <li>0x0000: 9600 baud</li> <li>0x0001: 19200 baud</li> <li>0x0002: 38400 baud</li> <li>0x0003: 56700 Baud</li> </ul>
Serial Setting - Parity	R/W	3	Uint16	<ul style="list-style-type: none"> <li>0x0000: None</li> <li>0x0001: Odd</li> <li>0x0002: Even</li> </ul>
Serial Setting - Stopbits	R/W	4	Uint16	<ul style="list-style-type: none"> <li>0x0001: 1 stop bit</li> <li>0x0002: 2 stop bits</li> </ul>
Device serial number	R	10	Char[10]	The serial number of the TORP sensor.
Firmware version	R	15	Char[10]	The installed firmware version.
System date and time	R/W	107	Uint32	Date and time in seconds since 1970/01/01. (Internal RTC with $\pm 0.9\%$ accuracy at 8.00MHz)
Device description	R/W	109	Char[64]	A user-defined device description. E.g. "Drain pipe south"
Index for Moving Average / Offset / Scaling	R/W	400	Uint16	The index of the parameter for the following offset and scaling settings. The parameter list is listed in this document from Modbus address 1000. <ul style="list-style-type: none"> <li>0x0000: ORP</li> </ul>
Postprocessing	R/W	200ff	Bool	see below (Scaling and offset table)
Moving average	R/W	401	Uint16	The number of samples for calculating the average concentration.

Name	R/W	Address	Data type	Data type Description
				Value range: 1 - 25. Default: 10
Offset	R/W	402	Float	Offset parameter. Formula: scaled = (raw - offset) * scaling
scaling	R/W	404	Float	Scaling parameter. Formula: scaled = (raw - offset) * scaling
ORP / ORP scaled	R	1000 / 1500	Float	
SQI / SQI scaled	R	1002 / 1502	Float	
Permanent errors	R	5100	Uint16	Errors that persist even after a restart. The error messages are described in the table below.
Permanent warnings	R	5101	Uint16	Warnings that remain even after a restart. The error messages are described in the table below.
Temporary errors	R	5102	Uint16	Errors that are reset after a restart. The error messages are described in a table below.
Temporary warnings	R	5103	Uint16	Warnings that are reset after a restart. The error messages are described in a table below.

### Write single register (0x06)

In contrast to most TRIOS sensors, the TORP does not assign any special meaning to the “Write single register” command.

### Report slave ID (0x11) Report slave ID (0x11)

The sensor name, serial number and firmware version are each reproduced as a zero-terminated ASCII character string.

T	R	I	O	S	0x0	T	O	R	P	0x0	0	7	1	0	0	0	0	0	0x0	1	.	0	.	8	0x0
---	---	---	---	---	-----	---	---	---	---	-----	---	---	---	---	---	---	---	---	-----	---	---	---	---	---	-----

### ErrorBits

	Bit No.	Device Driver	Description
Permanent Error	0	MEASUREMENT	Permanent measurement error
	1	MEAS_ADC_UPPERLIMIT	Upper limit of the measurement reached. Currently unused.

	Bit No.	Device Driver	Description
	2	MEAS_ADC_LOWERLIMIT	Lower limit of the measurement reached. Currently unused.
Temporary error	0	ADC_FULLSCALE	A/D converter full scale
	1	MEAS_ADC_UPPERLIMIT	A/D converter upper scale limit reached. Currently unused.
	2	MEAS_ADC_LOWERLIMIT	A/D converter lower end of scale reached. Currently unused.
	3		-
	4	FSM_STATE	FSM state General error
	5	FSM_TRANSITION	FSM transition error (invalid transition step)
	6	FSM_AUTHENTICATION	FSM authentication error (no authentication for secured actions (e.g. writing a manufacturer calibration))
	7		-
	8	FSM1_PARAMETER_METHOD	FSM1 parameter method error (unsupported calibration method)
9	FSM1_CALCULATE	FSM1 Calculate Error (calibration parameter could not be calculated)	
Temporary warning	0	TEMP_RED	Temperature outside the maximum specifications. Currently unused.
	1	TEMP_YEL	Temperature outside the recommended specification.
	2	PH_RED	ORP value outside the maximum specifications. Currently unused.
	3	PH_YEL	ORP value outside the recommended specification.
	4	REF_VOL_RED	Reference voltage value outside the maximum specification
	5	REF_VOL_YEL	Reference voltage value outside the recommended specification. Currently unused.
	6	SQI_RED	SQI value is < 0.5. Currently unused.

	<b>Bit No.</b>	<b>Device Driver</b>	<b>Description</b>
	7	SQI_YEL	SQI value is < 0.8. Currently unused.
Permanent warning	-		-

TriOS Mess- und Datentechnik GmbH  
Bgm.-Brötje-Str. 25 · 26180 Rastede · Deutschland  
Tel +49 (0)4402 69670-0  
Fax +49 (0)4402 69670-20  
[info@trios.de](mailto:info@trios.de)  
[www.trios.de](http://www.trios.de)